



Henman Trading











General Supplier for Hotel & Construction Industry

ADD.: RM3-306, UN PLAZA, LIUHE RD, HANGZHOU CITY, CHINA

Email : | shen@hztomax.com | sales@henmantrading.com |

Mobile / Whatsapp / wechat: 0086 15988447631 (for oversea call)

Product Catalog

	PVC VALVES	01-07
	UPVC DIN STANDARD WATER SUPPLY FITTINGS	08-14
	PVC PRESSURE FITTINGS WITH GASKET	15-19
	CPVC ASTM D2846 STANDARD WATER SUPPLY FITTINGS	20-25
	CPVC ASTM SCH80 STANDARD WATER SUPPLY FITTINGS	26-30
	PVC-U PRESSURE FITTING(SCH40)	31-34
	PVC-U PRESSURE FITTINGS(SCH80)	35-38
	PVC-U NBR 5648 WATER SUPPLY PIPE FITTINGS	39-42
	PVC FITTINGS FOR WATER DRAINAGE WITH EXPANDING(DIN)	43-44
	PVC-U THREADED FITTINGS FOR WATER SUPPLY(BS THREAD)	45-48
	PP COMPRESSION FITTINGS	49-53

PVC VALVES



NEW TYPE OCTAGONAL BALL VALVE

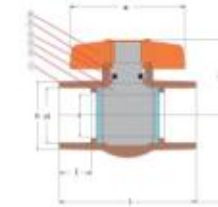

SIZE: 1/2"-8"
 END CONNECTOR: THREAD, SOCKET
 WORKING PRESSURE: 1.0MPA

Specification of material			
NO.	PART	MATERIAL	QTY
1	Body	UPVC	1
2	Seat Seal	EPDM	2
3	Ball	PP	1
4	O-Ring Seal	ABS	1
5	O-Ring	NBR	1
6	Handle	ABS	1

Dimensions														
Size	Nom	DIN/GB d1	BS d1	ANSI d1	JIS d1	BSPT Ths.In	NPT Ths.In	d	D	L	I	W	H1	H2
DN15(1/2")	20	22	21.34	22	14	14	14.5	29	74.5	20	69	64	44.9	
DN20(3/4")	25	26	26.67	26	14	14	20	35	85	22	74	73	52	
DN25(1")	32	34	33.4	32	11	11.5	24	43	99	25	88	86.5	65	
DN32(1-1/4")	40	42	42.16	38	11	11.5	30	52	108	25.5	101	97	70	
DN40(1-1/2")	50	48	48.26	48	11	11.5	34	60	124	29	110	108	73.5	
DN50(2")	63	60	60.33	60	11	11.5	44	75	141	35	126.5	127	81	
DN65(2-1/2")	75	76	73.03	76	11	8	56	90	183	53	201.5	190	108.5	
DN80(3")	90	89	88.9	89	11	8	71	107	227	66.5	201.5	182	116	
DN100(4")	110	114	114.3	114	11	8	86	129	272	72	243	219	151.5	
DN150(6")	160	165	168.3	165	11	8	130	187	390	100	300	310	180	
DN200(8")	200	216	219.1	216	11	8	154	227	420	105	300	380	190	

NEW TYPE OCTAGONAL BALL VALVE

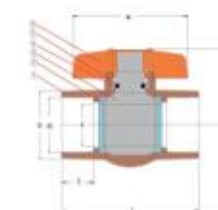

SIZE: 1/2"-8"
 END CONNECTOR: THREAD, SOCKET
 WORKING PRESSURE: 1.0MPA

Specification of material			
NO.	PART	MATERIAL	QTY
1	Body	UPVC	1
2	Seat Seal	EPDM	2
3	Ball	PP	1
4	O-Ring Seal	ABS	1
5	O-Ring	NBR	1
6	Handle	ABS	1

Dimensions														
Size	Nom	DIN/GB d1	BS d1	ANSI d1	JIS d1	BSPT Ths.In	NPT Ths.In	d	D	L	I	W	H1	H2
DN15(1/2")	20	22	21.34	22	14	14	14.5	29	74.5	20	69	64	44.9	
DN20(3/4")	25	26	26.67	26	14	14	20	35	85	22	74	73	52	
DN25(1")	32	34	33.4	32	11	11.5	24	43	99	25	88	86.5	65	
DN32(1-1/4")	40	42	42.16	38	11	11.5	30	52	108	25.5	101	97	70	
DN40(1-1/2")	50	48	48.26	48	11	11.5	34	60	124	29	110	108	73.5	
DN50(2")	63	60	60.33	60	11	11.5	44	75	141	35	126.5	127	81	
DN65(2-1/2")	75	76	73.03	76	11	8	56	90	183	53	201.5	190	108.5	
DN80(3")	90	89	88.9	89	11	8	71	107	227	66.5	201.5	182	116	
DN100(4")	110	114	114.3	114	11	8	86	129	272	72	243	219	151.5	
DN150(6")	160	165	168.3	165	11	8	130	187	390	100	300	310	180	
DN200(8")	200	216	219.1	216	11	8	154	227	420	105	300	380	190	

COMPACT BALL VALVE

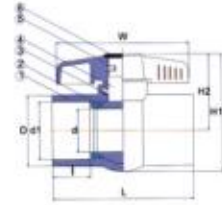

SIZE: 1/2"-8"
END CONNECTOR: THREAD, SOCKET
WORKING PRESSURE:1.0MPA

Specification of material			
NO.	PART	MATERIAL	Q'TY
1	Body	PVC, CPVC, PP	1
2	Seat Seal	TPV	1
3	O-Ring	EPDM, FPM(NBR)	2
4	Ball	PVC, CPVC, PP	2
5	Handle	PP, ABS, PVC	2
6	Cap	PP, ABS, PVC	2

Dimensions														
Size	Nom	DIN/GB d1	BS d1	ANSI d1	JIS d1	BSPT Thd.in	NPT Thd.in	d	D	L	I	W	H1	H2
DN15(1/2")	20	22	21.34	22	14	14	14.5	29	74.5	20	69	64	44.9	
DN20(3/4")	25	26	26.67	26	14	14	20	35	85	22	74	73	52	
DN25(1")	32	34	33.4	32	11	11.5	24	43	99	25	88	86.5	65	
DN32(1-1/4")	40	42	42.16	38	11	11.5	30	52	108	25.5	101	97	70	
DN40(1-1/2")	50	48	48.26	48	11	11.5	34	60	124	29	110	108	73.5	
DN50(2")	63	60	60.33	60	11	11.5	44	75	141	35	126.5	127	81	
DN65(2-1/2")	75	76	73.03	76	11	8	56	90	183	53	201.5	190	108.5	
DN80(3")	90	89	88.9	89	11	8	71	107	227	66.5	201.5	182	116	
DN100(4")	110	114	114.3	114	11	8	86	129	272	72	243	219	151.5	
DN150(6")	160	165	168.3	165	11	8	130	187	390	100	300	310	180	
DN200(8")	200	216	219.1	216	11	8	154	227	420	105	300	380	190	

TRUE UNION BALL VALVE

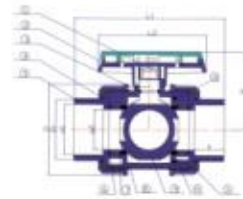

SIZE: 1/2"-4"
END CONNECTOR: THREAD, SOCKET
WORKING PRESSURE:1.0MPA

Specification of material							
NO.	PART	MATERIAL	Q'TY	NO.	PART	MATERIAL	Q'TY
1	Stem	PVC,CPVC,PP	1	7	O-Ring	EPDM, FPM(NBR)	2
2	Handle	ABS	1	8	Body	PVC,CPVC,PP	1
3	Stem O-Ring	EPDM, FPM(NBR)	2	9	Ball	PVC, CPVC, PP	1
4	Union Nut	PVC, CPVC, PP	2	10	Seat Seal	PTFE	2
5	End Connector	PVC,CPVC, PP	2	11	Seat Carrier	PVC,CPVC, PP	1
6	Body O-Ring	EPDM, FPM(NBR)	2	12	Carrier O-Ring	EPDM, FPM(NBR)	1

Dimensions														
Size	Nom	DIN/GB d1	BS d1	ANSI d1	JIS d1	BSPT Thd.in	NPT Thd.in	d2	D1	D	I	L1	L2	H
DN15(1/2")	20	22	21.34	22	14	14	14	27.6	51.2	20.6	112.5	65	50.5	
DN20(3/4")	25	26	26.67	26	14	14	14	18.7	35.6	65.5	24.6	130.2	75	58.5
DN25(1")	32	34	33.4	32	11	11.5	24	41.6	73.7	28	142.5	85	65.7	
DN32(1-1/4")	40	42	42.16	38	11	11.5	32	52	86.6	31	161	97	76.5	
DN40(1-1/2")	50	48	48.26	48	11	11.5	40	59.5	102	31.5	166.5	110	86	
DN50(2")	63	60	60.33	60	11	11.5	50	75	120	40	214	133.5	101.5	
DN65(2-1/2")	75	76	73.03	76	11	8	60	87.5	135	40	228	161	112.5	
DN80(3")	90	89	88.9	89	11	8	79	107.5	188	48	269	200	160.5	
DN100(4")	110	114	114.3	114	11	8	99	132	216	56	309	240	173.5	

SINGLE UNION BALL VALVE

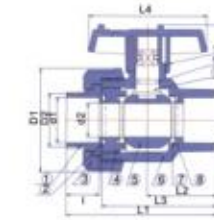

SIZE: 1/2"-4"
END CONNECTOR: THREAD, SOCKET
WORKING PRESSURE:1.0MPA

Specification of material							
NO.	PART	MATERIAL	Q'TY	NO.	PART	MATERIAL	Q'TY
1	End Connector	PVC,CPVC,PP	1	7	Seat Seal	PTFE	2
2	Carrier O-Ring	EPDM, FPM(NBR)	1	8	O-Ring	EPDM, FPM(NBR)	2
3	Union Nut	PVC,CPVC,PP	1	9	Stem	PVC,CPVC,PP	1
4	Seat Carrier	PVC,CPVC,PP	1	10	Stem O-Ring	EPDM, FPM(NBR)	2
5	Ball	PVC,CPVC,PP	1	11	Handle	PP,ABS,PVC	1
6	Body	PVC,CPVC,PP	1				

Dimensions																		
Size	Nom	DIN/GB d1	BS d1	ANSI d1	JIS d1	BSPT Thd.in	NPT Thd.in	d2	D2	D1	I	L1	L2	L3	L4	H		
DN15(1/2")	20	22	21.34	22	14	14	14	27.6	51.3	20.6	95.8	25.3	67.3	65	49.5			
DN20(3/4")	25	26	26.67	26	14	14	14	18.7	35.2	65.5	25	112	32.4	78.3	74.9	56.5		
DN25(1")	32	34	33.4	32	11	11.5	24	41.6	73.7	27.9	121.5	49.5	85.9	85	65			
DN32(1-1/4")	40	42	42.16	38	11	11.5	32	49	86.6	27	130	57	99	97.1	76.5			
DN40(1-1/2")	50	48	48.26	48	11	11.5	40	60.8	102	34.5	157.5	69	113.5	109.7	86.5			
DN50(2")	63	60	60.33	60	11	11.5	50	74.5	120	40	190	81	136.5	133.5	102.5			
DN65(2-1/2")	75	76	73.03	76	11	8	60	89	135	40	210	95.9	156	161	113.5			
DN80(3")	90	89	88.9	89	11	8	79	107.5	188	48	254.6	120.9	196.5	199.4	161.5			
DN100(4")	110	114	114.3	114	11	8	99	132	215.5	56	294	140.7	225	240	174			

BUTTERFLY VALVE

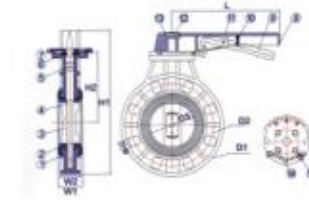

SIZE: 1/2"-8"
END CONNECTOR: FLANGE
WORKING PRESSURE:1.0MPA

Specification of material							
NO.	PART	MATERIAL	Q'TY	NO.	PART	MATERIAL	Q'TY
1	Body	PVC	1	9	Small Handle	ABS	1
2	Seat Seal	EPDM, FPM(NBR)	1	10	Spring	SUS304	1
3	Gate	PVC	1	11	Pin	SUS304	1
4	Stem	SUS410	1	12	Bolt	SUS304	1
5	O-Ring	EPDM, FPM(NBR)	2	13	Handle Cap	ABS	1
6	Washer	ABS	1	14	Insered Bolt	SUS304	4
7	Locking Plate	PVC	1	15	Bolt cap	PVC	4
8	Large Handle	ABS	1				

Dimensions																
Size	Nom	D1	DIN/GB d1	JIS d1	ANSI d1	D3	D4	L	H1	H2	W1	W2	DIN n-e	JIS n-e	ANSI n-e	
DN50(2")	160.1	120	100	120.4	55.6	99.7	189.7	223.3	98.3	44	32	4-20	4-19	4-19		
DN65(2-1/2")	179.8	141.2	140	139.5	68.7	99.7	189.0	247.0	111.6	48.3	32.4	4-18	4-19	4-19		
DN80(3")	195.0	156.4	140	139.5	83.9	99.7	238.5	282.6	132.5	51.9	36.3	8-20	4-19	4-19		
DN100(4")	228.1	183	150	152.4	103.2	99.7	239.5	319.4	155.4	54.5	44.1	8-20	8-19	8-19		
DN125(5")	257	210.9	175	190.5	129.5	139	309.8	368	170.3	66.5	54.6	8-21.5	8-19	8-19		
DN150(6")	285.4	238.5	240	241.5	151.1	140.0	309.8	400.8	187.5	73.1	56.4	8-24	8-23	8-22		
DN200(8")	342.6	292.4	295	298.5	198.6	140.0	309.8	473.0	230.1	92.0	72.2	8-24	12-23	8-23		

FOOT VALVE

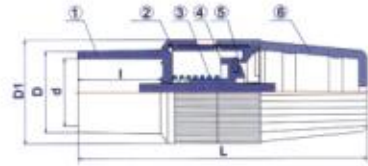

SIZE: 1/2"-2"
END CONNECTOR: THREAD, SOCKET
WORKING PRESSURE: 1.0MPA

Specification of material										
NO.	PART	MATERIAL	Q'TY							
1	Body	PVC	1							
2	Connector	EPDM, FPM(NBR)	1							
3	Spring	STAINLESS STEEL	1							
4	Gate	PVC	1							
5	Seal	EPDM, FPM(NBR)	1							
6	Body	PVC	1							

Dimensions											
Size	Nom	DIN/GB d1	BS d1	ANSI d1	JIS d1	BSPT Thd./in	NPT Thd./in	D	D1	I	L
DN15(1/2")	20	22	22	21.34	22	14	14	31	43.7	31.0	137
DN20(3/4")	25	26	26	26.67	26	14	14	35.5	43.7	32.5	141
DN25(1")	32	34	34	33.4	32	11	11.5	41	55.1	35	148
DN32(1-1/4")	40	42	42	42.16	38	11	11.5	50	79	47	195
DN40(1-1/2")	50	48	48	48.26	48	11	11.5	63	92	41	205
DN50(2")	63	60	60	60.33	60	11	11.5	75	105	52	226

FOOT VALVE

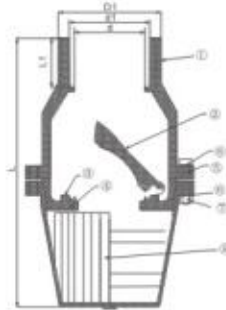

SIZE: 2 1/2"-6"
END CONNECTOR: THREAD, SOCKET
WORKING PRESSURE: 1.0MPA

Specification of material										
NO.	PART	MATERIAL	Q'TY							
1	Exit Body	PVC	1							
2	Gate	PVC	1							
3	Disk	PVC	1							
4	Sheet Gasket	EPDM, FPM(NBR)	1							
5	Bolt	SUS304	1							
6	Body	SUS304	2							
7	Washer	SUS304	1							
8	Entrance Body	PVC	1							

Dimensions										
Size	Nom	DIN/GB d1	BS d1	ANSI d1	JIS d1	d	D1	L1	L	
DN65(2-1/2")	75	76	76	73.03	76	68.3	90	43	248	
DN80(3")	90	89	89	88.9	89	85	105	57	295	
DN100(4")	110	114	114	114.3	114	96	129	61	340	
DN150(6")	160	168.3	168.3	168.3	165	152	181	89	458	

PVC SWING CHECK VALVE

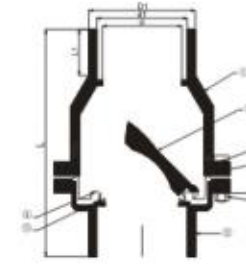

SIZE: 2 1/2"-6"
END CONNECTOR: THREAD, SOCKET
WORKING PRESSURE: 1.0MPA

Specification of material										
NO.	PART	MATERIAL	Q'TY							
1	Exit Body	PVC	1							
2	Entrance Body	PVC	1							
3	Gate Nut	PVC	1							
4	Disk	PVC	1							
5	Sheet Gasket	EPDM, FPM(NBR)	1							
6	Bolt	SUS304	1							
7	Nut	SUS304	1							
8	Washer	SUS304	2							

Dimensions										
Size	Nom	DIN/GB d1	BS d1	ANSI d1	JIS d1	d	D1	L1	L	
DN65(2-1/2")	75	76	76	73.03	76	68.3	90	43	220	
DN80(3")	90	89	89	88.9	89	85	105	57	263	
DN100(4")	110	114	114	114.3	114	96	129	61	274	
DN150(6")	160	166	166	168.3	165	152	181	89	391	

SPING BALL FOOT VALVE



SIZE 1/2" 3/4" 1" 1-1/4" 1-1/2" 2"

FLANGE SWING CHECK VALVE



SIZE 5" 8"

NEW BALL VALVE



SIZE 1/2" 3/4" 1" 1-1/4" 1-1/2" 2"

OLTAGONAL BALL VALVE



SIZE 1/2" 3/4" 1" 1-1/4" 1-1/2" 2"
2-1/2" 3" 4" 6"

COMPACT BALL VALVE LONG HANDLE



SIZE 2-1/2" 3" 4"

COMPACT BALL VALVE LONG HANDLE



SIZE 2-1/2" 3" 4"

UPVC ELECTRIC ACTUATOR
BUTTERFLY VALVE



SIZE	
2"	2-1/2"
3"	4"
5"	6"
8"	10"
12"	16"

UPVC PNEUMATIC ACTUATOR
BUTTERFLY VALVE



SIZE	
2"	2-1/2"
3"	4"
5"	6"
8"	10"
12"	16"

UPVC BUTTERFLY GEAR VALVE



SIZE	
2"	2-1/2"
3"	4"
5"	6"
8"	10"
12"	16"

SOCKET BUTTERFLY
VALVE



SIZE	
4"	5"
6"	8"

NEW BUTTERFLY VALVE



SIZE	
2"	2-1/2"
3"	4"
5"	6"
8"	10"
12"	16"

UPVC DIN STANDARD WATER SUPPLY FITTINGS



45° ELBOW

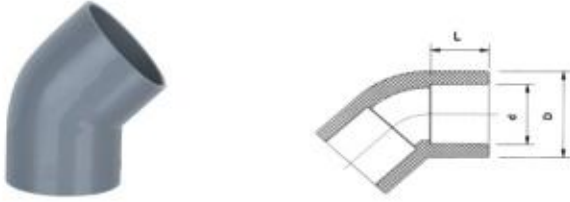

Product data

Size	Nom	D	d	L
20	25	25	20	17
25	30.8	30.8	25	19.5
32	38.3	38.3	32	23
40	47.9	47.9	40	28.5
50	58.3	58.3	50	33.5
63	72.9	72.9	63	40
75	87.6	87.6	75	44
90	105.4	105.4	90	51
110	122	122	110	60
125	137	137	125	69
160	176	176	160	89
200	217	217	200	104
250	212	250	250	135
315	342	315	315	163.5
400	435	400	400	205

90° ELBOW

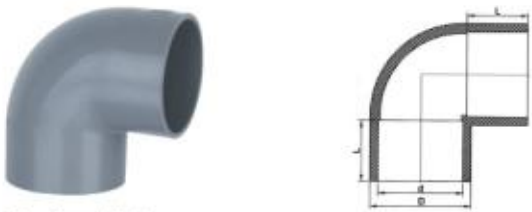

Product data

Size	Nom	D	d	L
20	25	25	20	17
25	30.8	30.8	25	19.5
32	38.3	38.3	32	23
40	47.9	47.9	40	28.5
50	58.3	58.3	50	33.5
63	72.9	72.9	63	40
75	87.6	87.6	75	44
90	105.4	90	90	51
110	122	110	110	60
125	138	125	125	69
160	174.5	160	160	87
200	219.5	200	200	108
250	273	250	250	135
315	343	315	315	165
400	429	400	400	205

FEMALE COUPLING



Product data

Size	Nom	D	d	G	L	H	d1
20	27.4	20	1/2"	16	32	31.6	
25	33.2	25	3/4"	19	38	38.3	
32	40.6	32	1"	22	44.7	47.5	
40	49.3	40	1 1/4"	26	53	56.9	
50	60.3	50	1 1/2"	31.5	55.2	69.6	
63	85.8	63	2"	38	69	85.8	

TEE

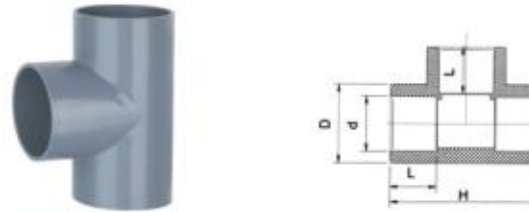

Product data

Size	Nom	D	d	L	H
20	25	25	20	17	57
25	31.2	25	19.5	19.5	67
32	38.3	32	23	23	81
40	47.9	40	28.5	28.5	102
50	58.3	50	33.5	33.5	123
63	72.9	63	40	40	148
75	87.6	75	44	44	166
90	105.4	90	51	51	196
110	121.5	110	62.2	62.2	235.5
125	137.5	125	69	69	267
160	179	160	86.5	86.5	336
200	220	200	108	108	421
250	272	250	135	135	531
315	342	315	162	162	645
400	433	400	208	208	665

REDUCING COUPLING



Product data

Size	Nom	D	D1	L	d	d1	l	H
25X20	30.8	25	19.5	25	20	17	43	
32X20	38.3	32	23	25	20	17	48	
32X25	38.3	32	23	30.8	25	19.5	50.5	
40X20	47.9	40	28.5	25	20	17	54.5	
40X25	47.9	40	28.5	30.8	25	19.5	56.5	
40X32	47.9	40	28.5	38.3	32	23	60	
50X20	58.3	50	33.5	25	20	17	62	
50X25	58.3	50	33.5	30.8	25	19.5	63.8	
50X32	58.3	50	33.5	38.3	32	23	68	
50X40	58.3	50	33.5	47.9	40	28.5	72	
63X25	72.9	63	40	30.8	25	19.5	75	
63X32	72.9	63	40	38.3	32	23	79	
63X40	72.9	63	40	47.9	40	28.5	83	
63X50	72.9	63	40	58.3	50	33.5	88	
75X40	87.6	75	44	47.9	40	28.5	91.5	
75X50	87.6	75	44	58.3	50	33.5	96	
75X63	87.6	75	44	72.9	63	40	101	
90X40	105.4	90	51	47.9	40	28.5	103	
90X50	105.4	90	51	58.3	50	33.5	106.5	
90X63	105.4	90	51	72.9	63	38.5	114	
90X75	105.4	90	51	87.6	75.4	44	119.5	
110X50	122	110	64	57	50	32.5	125.5	
110X63	122	110	62	71	63	38	128.5	
110X75	122	110	64	84	75	44	126	
110X90	122	110	65	100	90	52.2	127	
125X63								
125X75	137.5	125	71	84.5	75	45	144	
125X90	137.2	125	71	101	90	52.5	141.5	
125X110	137.2	125	71	121	110	62	140	
160X90	175	160	89	100	90	59	185	
160X110	175	160	91	122	110	66.5	184	
160X125	174.5	160	89	137	125	77	184	
200X110	220	200	113	122	110	58	220	
200X160	219.5	200	112	174	160	80	219	
250X110	271	250	135	122	110	62	263	
250X160	271	250	135	175	160	98	272	
250X200	272	250	130	218	200	108	273	
315X110	338	315	160	128	110	62	378	
315X160	340	315	159	180	160	86	375	
315X200	340	315	160	221	200	108	360	
315X250	341	315	158	271.5	250	133	352	
400X200	427	400	205	273	200	128	400	
400X250	433	400	203	221	250	108	463	
400X315	433	400	203	345	315	164	436	

REDUCING TEE



Product data

Size	Nom	D	d	L	D1	d1	l	H
25X20	30.8	25	19.5	25	20	17	64	
32X20	38.3	32	23	25	20	17	69	
32X25	38.3	32	23	30.8	25	19.5	79	
40X20	47.9	40	28.5	25	20	17	82	
40X25	47.9	40	28.5	30.8	25	19.5	90	
40X32	47.9	40	28.5	38.3	32	23	92	
50X20	58.3	50	33.5	25	20	17	91	
50X25	58.3	50	33.5	30.8	25	19.5	98	
50X32	58.3	50	33.5	38.3	32	23	105	
50X40	58.3	50	33.5	47.9	40	28.5	110	
63X25	72.9	63	40	30.8	25	19.5	110	
63X32	72.9	63	40	38.3	32	23	118	
63X40	72.9	63	40	47.9	40	28.5	125	
63X50	72.9	63	40	58.3	50	33.5	140	
75X40	87.6	75	44	47.9	40	28.5	137	
75X50	85	75	46.6	57	50	34.2	143	
75X63	87.6	75	44	72.9	63	40	143	
90X40	105.4	90	51	47.9	40	28.5	151	
90X50	105.4	90	51	58.3	50	33.5	159	
90X63	105.4	90	51	72.9	63	38.5	172	
90X75	105.4	90	51	87.6	75.4	44	186	
110X50	122	110	63	58	50	54.1	176.7	
110X63	121	110	63	72	63	40	143	
110X75	122	110	63	86	75	40	176.7	
110X90	122	110	62	110	90	45	190	
125X63	139	125	71	72	63	43	200	
125X75	137.5	125	68	85	75	44	219	
125X90	137	125	68	100	90	52	221	
125X110	138.5	125	68.5	122	110	61	216	
160X90	176	160	87	101.5	90	53.5	230	
160X110	176	160	86	122	110	63	249	
200X110	220	200	108	122	110	63.5	264	
200X160	220	200	108.3	176	160	87.5	285	
250X110	272	250	130.5	122	110	63	329.2	
250X160	272	250	130	177	160	91	377	
250X200	275	250	132	220	200	105	375.5	
315X110	343	315	160	127	110	62	226	
315X160	341	315	165	178	160	89	473	
315X200	340	315	159	222	200	105.5	447	
315X250	342	315	163	273	250	134	495	
400X200	433	400	203	221	200	108	530	
400X250	433	400	205	272	250	110	581	
400X315	433	400	208	331	315	112	616	

COPPER THREAD COUPLING(FEMALE COUPLING)

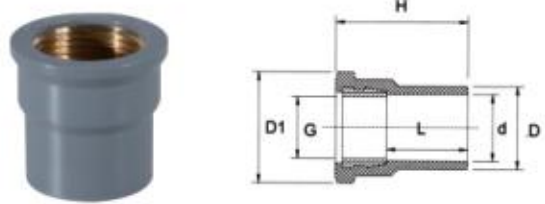

Product data

Size	Nom	D	d	D1	G	L	H
20X1/2"	25	20	33.5	1/2"	24.5	40	
25X1/2"	30.8	25	35.3	1/2"	19.5	43	
25X3/4"	30.8	25	40.4	3/4"	28	45	
32X1/2"	38.3	32	33.5	1/2"	23	43	
32X3/4"	38.3	25	44.2	3/4"	23	47	
32X1"	38.3	32	50	1"	23	49	

90° COPPER THREAD ELBOW(FEMALE ELBOW)



Product data

Size	Nom	D	d	D1	G	L
20X1/2"	25	20	33	1/2"	17	
25X1/2"	30.8	25	33	1/2"	19.5	
25X3/4"	30.8	25	40	3/4"	19.5	
32X1/2"	38.3	32	33	1/2"	23	
32X3/4"	38.3	25	40	3/4"	23	
32X1"	38.3	32	45	1"	23	

COPPER THREAD TEE(FEMALE TEE)

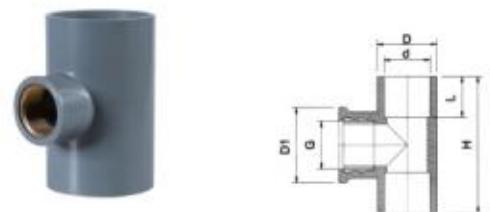

Product data

Size	Nom	D	d	D1	G	L	H
20X1/2"	25	20	33	1/2"	17	60	
25X1/2"	30.8	25	33	1/2"	19.5	68	
25X3/4"	30.8	25	40	3/4"	19.5	73	
32X1/2"	38.3	32	33	1/2"	23	68	
32X3/4"	38.3	25	40	3/4"	23	73	
32X1"	38.3	32	45	1"	23	90	

REDUCING RING



Product data

Size	Nom	D	d	L	H
25X20	25	20	17	20.5	
32X25	32	25	20	25	
40X32	40	32	25	28.5	
50X40	50	40	27.5	33.5	
63X32	63	32	21.7	37.5	
63X50	63	50	32.5	40	
90X63	90	63	38	51.3	
110X63	110	63	38.4	53.2	
110X75	110	75	45	53.2	
110X90	110	90	46.7	59.6	
160X110	160	110	58.6	85.2	

END CAP

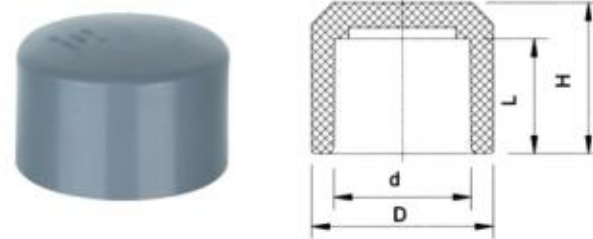

Product data

Size	Nom	D	d	L	H
20	26.2	20	19	24	
25	31.2	25	21.5	27	
32	38.5	32	29.5	31	
40	47.4	40	28.2	35	
50	58.5	50	33	40	
63	72.4	63	40	47	
75	88.2	75	46	53.6	
90	105.4	90	51	63.3	
110	121.2	110	65.5	78	
125	137.5	125	71.2	85.6	
160	115	160	88	115	
200	219	200	111	144.6	
250	270	250	130	180	
315	337	315	165	250	
400	428	400	205	337	

MALE ADAPTOR

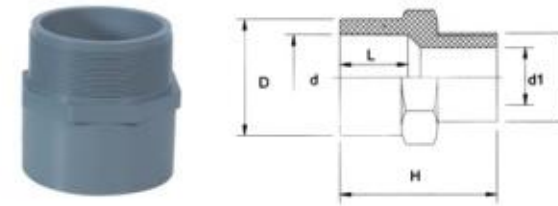

Product data

Size	Nom	D	d	G	L	H	d1
20	27.4	20	1/2"	16	37	14	
25	33.2	25	3/4"	19	43	18.5	
32	40.6	32	1"	23	50.7	25	
40	49.3	40	1 1/4"	26	58	32	
50	60.3	50	1 1/2"	31.5	61	36	
63	85.8	63	2"	38	73	47	
90	105.7	90	3"	51.7	107.5	69	

COUPLING

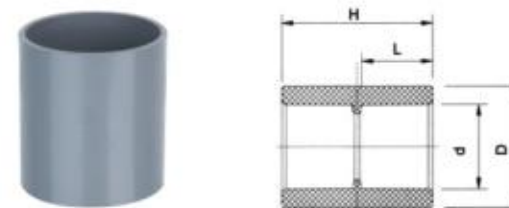

Product data

Size	Nom	D	d	L	H
20	25	20	17	36	
25	30.8	25	19.5	41	
32	38.3	32	23	48	
40	47.9	40	28.5	60	
50	58.3	50	33.5	70	
63	72.9	63	40	83	
75	87.6	75	44	92	
90	100	52	51	105	
110	121		61	127	
125	137		68	142	
160	175		87.5	108.5	
200	218.5		102	225	
250	272		134	277	
315	342		164	330	
400	428		205	417	

REPAIRING COUPLING (NO STOP WATER)

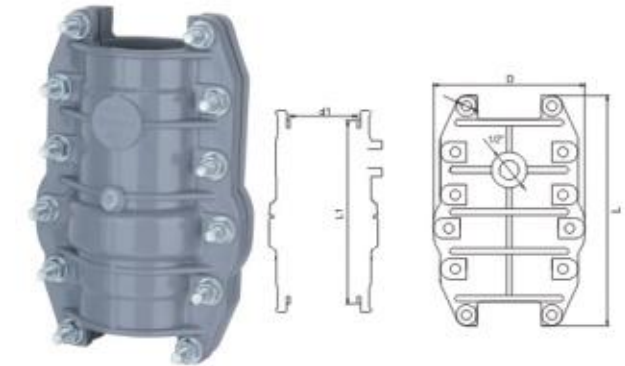

Product data

Size	Nom	L	L1	D	d1
φ20	90	61	62	20	
φ25	100	69	67	25	
φ32	123	82	84	32	
φ40	161	119	93	40	
φ50	199	148	115	50	
φ63	258	184	160	63	
φ75	266	198	172	75	
φ90	314	233	204	90	
φ110	338	250	233	110	
φ125	358	261	253	125	
φ140	366	267	271	140	
φ160	377	293	297	160	
φ200	452	362	338	200	
φ250	474	387	420	250	
φ315	469	393	498	315	
φ400	537	451	610	400	

UNION

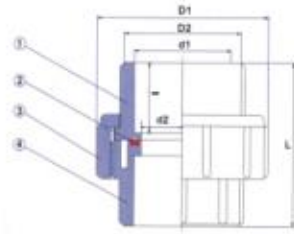

SIZE: 1/2"-4"
END CONNECTOR: THREAD, SOCKET
WORKING PRESSURE: 1.0MPA

Specification of material			
NO.	PART	MATERIAL	Q'TY
1	End Connector	PVC, CPVC	1
2	O-Ring	EPDM, FPM(NBR)	1
3	Union Nut	PVC, CPVC	1
4	Body	PVC, CPVC	1

Dimensions												
Size	Nom	DIN/GB d1	BS d1	ANSI d1	JIS d1	BSPT Thd.in	NPT Thd.in	d2	D2	D1	l	L
DN15mm(1/2")	15	20	22	21.34	22	14	14	14	25	40	21	49
DN20mm(3/4")	20	25	26	26.67	26	14	14	19	32	48	22	53
DN25mm(1")	25	32	34	33.4	32	11	11.5	24	40	55	28	62
DN32mm(1-1/4")	32	40	42	42.16	38	11	11.5	32	52	70	29	65
DN40mm(1-1/2")	40	50	48	48.26	48	11	11.5	40	60	81	30	80
DN50mm(2")	50	63	60	60.33	60	11	11.5	45	72	100	38	95
DN65(2-1/2")	65	75	76	73.03	76	11	8	60	90	129	40	109
DN80mm(3")	80	90	89	88.9	89	11	8	80	103.5	145.5	48	125.5
DN100mm(4")	100	110	114	114.3	114	11	8	100	132.5	175	60	160

TS FLANGE

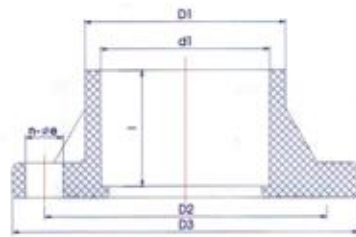

SIZE: 1/2"-8"
END CONNECTOR: THREAD, SOCKET
WORKING PRESSURE: 1.0MPA

Dimensions										
Size	Nom	D1	D2	D3	DIN/GB d1	BS d1	ANSI d1	JIS d1	l	n-φe
20mm(1/2")	20	31	65	93	20	22	21.34	22	21	4-14
25mm(3/4")	25	36	75	103	25	26	26.67	26	25	4-14
32mm(1")	32	46.0	85	114	32	34	33.4	32	21	4-14
40mm(1-1/4")	40	55	100	138	40	42	42.16	38	23	4-17
50mm(1-1/2")	50	58.0	108	140	50	48	48.26	48	35	4-19
63mm(2")	63	72	125	163	63	60	60.33	60	43	4-19
75(2-1/2")	75	85	145	182	75	76	73.03	76	47	4-19
90mm(3")	90	101	160	195	90	89	88.9	89	56	8-20
110mm(4")	110	124	180	215	110	114	114.3	114	64	8-20
125mm(5")	125	145	195	245	125				75	8-28
160mm(6")	160	175	240	280	160	168.3	168.3	165	92	8-24
200mm(8")	200	222	293	334	200	219.1	219.1	216	115	8-21

SHORT PIPE FOR FLANGE

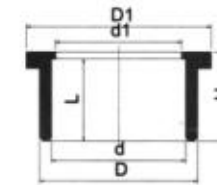

Dimensions						
NOM.	d	D	L	H	D1	d1
φ63(2")	63	73	45	50	95	62
φ75(2-1/2")	75	86	50	55	109	73
φ90(3")	90	104	54	60	123	88
φ110(4")	110	123	62	76	150	104
φ160(6")	160	177	91	84	199	157
φ200(8")	200	222	109	129	255	197
φ250(10")	250	273	132	147	303	247
φ315(12")	315	342	163	184	370	310
φ400(16")	400	428	205	222	461	391

PLANE FLANGE

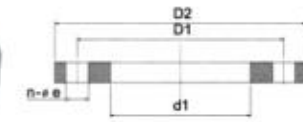

Dimensions					
NOM.	D1	D2	d1	H	n-φe
φ63(2")	124	158	96	17	4-19
φ75(2-1/2")	145	181	110	18	4-19
φ90(3")	159	192	126	20	4-19
φ110(4")	179	218	152	20	8-19
φ160(6")	239	281	204	25	8-22
φ200(8")	339	295	256	33	8-22
φ250(10")	389	373	306	37	12-22
φ315(12")	401	440	371	41	12-22
φ400(16")	536	567	435	44	16-31

COMPRESSION COUPLING

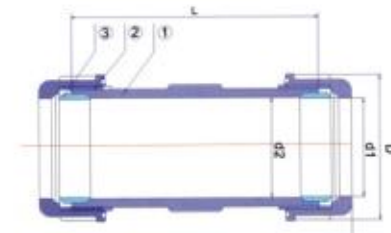

SIZE: 1/2"-2"
END CONNECTOR: THREAD, SOCKET
WORKING PRESSURE: 1.0MPA

Specification of material			
NO.	PART	MATERIAL	Q'TY
1	Body	PVC	1
2	Union Nut	PVC	2
3	Seat	EPDM, FPM(NBR)	2

Dimensions								
Size	Nom	DIN/GB d1	BS d1	ANSI d1	JIS d1	d2	D	L
15mm(1/2")	15	20	22	21.34	22	23	39	105
20mm(3/4")	20	25	26	26.67	26	28	46	112
25mm(1")	25	32	34	33.4	32	36	53	122
32mm(1-1/4")	32	40	42	42.16	38	44	61	143
40mm(1-1/2")	40	50	48	48.26	48	52	75	164
50mm(2")	50	63	60	60.33	60	64.5	90	195
65(2-1/2")	65	75	76	73.03	76	78	108	220
80mm(3")	80	90	89	88.9	89	93	121	268
100mm(4")	100	110	114	114.3	114	117.2	143	330
125mm(5")	125					128.5	164	326
160mm(6")	160	168.3	168.3	165	163	207	384	

PVC PRESSURE FITTINGS WITH GASKET

ONE FAUCETONE INSERT 90°ELBOWL A01

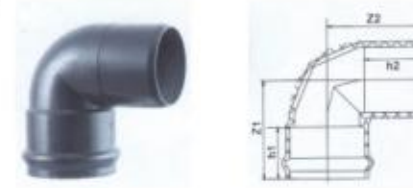

Spec	Z1	Z2	h1	h2
225	312	296	166	170
250	337.5	340	182	178
315	393	378	198	222

TWO FAUCET 90°ELBOW A02



Spec	Z	h
63	112	76
75	123	81.5
90	165	114
110	190	122
160	229	142
200	266	153
225	312	163
250	338	177
315	393	198
355	393	206

TWO FAUCET COUPLING A03

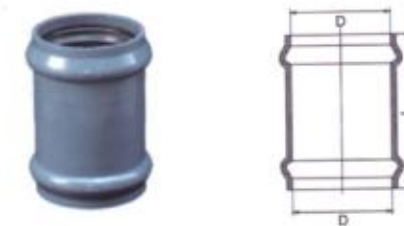

Spec D	L
63	156
75	170
90	235
110	266
160	310
200	338
225	360
250	385
315	460
355	460

TWO FAUCET 45°ELBOW A04



Spec D	Z	h
63	92	76
75	103.5	81.5
90	136	114
110	162.5	122
160	183	141.5
200	210	155
225	222	166
250	248	180
315	298	196
355	292	206

THREE FAUCET REGULAR TEE A05

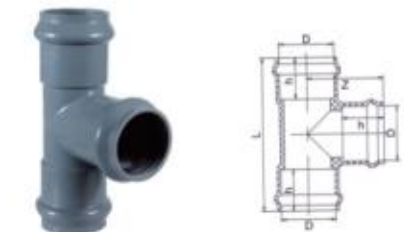

Spec D	L	h	Z
63	224	76	112
75	245	81.5	122.5
90	330	115	165
110	410	122	206
160	473	141.5	238
200	560	152	280
225	615	166	308
250	666	176	333
315	780	198	390
355	786	206	393

REPAIRING JOINT A06



Spec D	L	H
110	305	221
160	365	252
200	410	290
225	/	315
250	430	335
315	/	390

**TWO FAUCET ONE FLANGE REGULAR TEE
A07**

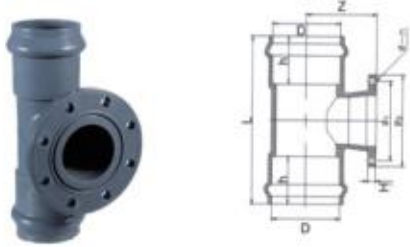

Spec D	L	h	z	phi1	phi2	H	phi-n
110	413	122	158	180	225	21	17.5-8
160	475	141.5	191	240	285	24	22-8
200	560	155	217.5	295	340	28	22-8
225	611	166	260	295	340	30	22-8

**TWO FAUCET ONE FLANGE REDUCING TEE
A08**

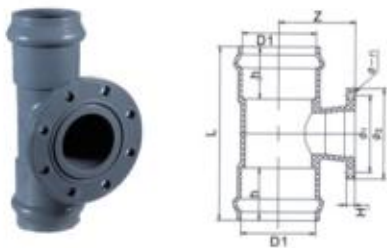

Spec D1xD2	L	h	z	phi1	phi2	H	phi-n
160x110	428	141.5	191	180	225	21	17.5-8
200x110	475	155	210	180	225	21	17.5-8
200x160	535	155	216.5	240	285	24	22-8
225x110	490	166	225	180	225	21	17.5-8
225x160	540	166	230	240	285	24	22-8
250x110	520	180	238	180	225	21	17.5-8
250x160	573	180	240	240	285	24	22-8
250x200	623	180	260	295	340	28	22-8
315x110	580.5	198	279	180	225	21	17.5-8
315x160	618	198	277	240	285	24	22-8
315x200	663	198	292	295	340	28	22-8

**COOPER SCREW BLANK FLANGE
A09**



Spec D	d1	d2	d3	H	H1	L	phi-n
110x2"	170	180	225	38	20	28	17.5x8
160x2"	230	240	285	41.5	25	28	17.5x8
200x2"	295	340	43	28	28	22x8	

**ONE FAUCET ONE FLANGE ONE INSERT
REDUCING TEE
A10**

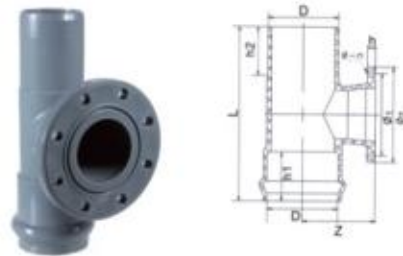

Spec D	L	h1	h2	h	phi1	phi2	Z	phi-n
110	410	122	127	21	180	225	158	17.5x8
160	480	141.5	144	24	240	285	191	22x8
200	560	155	155	28	295	340	217.5	22x8
225	615	166	167	30	295	340	260	22x8

**ONE FAUCET ONE FLANGE ONE INSERT
REDUCING TEE
A11**

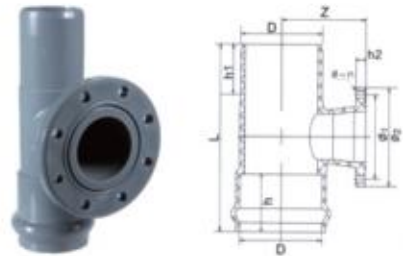

Spec D	L	h1	h2	h	phi1	phi2	Z	phi-n
160x110	440	141.5	144	21	180	225	191	17.5x8
200x110	477	155	155	21	180	225	210	17.5x8
200x160	530	155	155	24	240	285	216.5	22x8
225x110	495	166	167	21	180	225	225	17.5x8
225x160	550	166	167	24	240	285	230	22x8
250x110	515	180	182	21	180	225	238	17.5x8
250x160	570	180	182	24	240	285	240	22x8
250x200	616	180	180	28	295	340	260	22x8
315x110	575	198	197	21	180	225	279	17.5x8
315x160	618	198	197	24	240	285	277	22x8
315x200	663	198	197	28	295	340	292	22x8

**BLANK FLANGE
A12**



Spec D	d1	d2	d3	h	n	R
110	170	180	225	20	8	11
160	230	240	285	25	8	9
200	295	340	40	28	8	11

**TWO FAUCET ONE INSERT REGULAR TEE
A13**

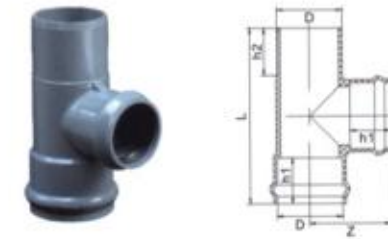

Spec D	L	h1	h2	Z
110	410	122	130	206
160	480	141.5	144	238
200	560	155	155	280
225	615	166	167	308
250	670	180	182	333
315	780	198	198	390

**TWO FAUCET ONE INSERT REDUCING TEE
A14**



Spec D1XD2	L	h1	h2	h3	Z
160x110	440	141.5	122	144	220
200x110	477	155	122	155	235
200x160	530	155	141.5	155	255
225x110	495	166	122	167	250
225x160	550	166	141.5	167	270
250x110	515	180	122	182	265
250x160	570	180	141.5	182	285
250x200	616	180	155	182	315
315x110	575	198	122	197	312
315x160	618	198	141.5	197	318
315x200	663	198	155	197	344

**ONE FAUCET ONE INSERT COPPER
SCREW TEE
A15**

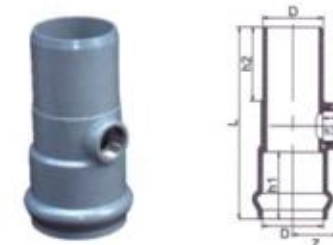

Spec DXRp	L	h1	h2	h3	Z
110x2"	340	122	130	28	81
160x2"	380	141.5	144	28	103
200x2"	410	155	155	28	122.5

**THREE FAUCET REDUCING TEE
A16**

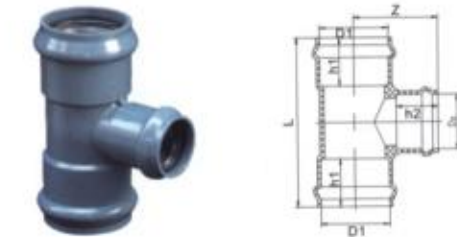

Spec D1XD2	L	h1	h2	Z
75x63	234	81.5	76	117.5
90x63	304	115	76	128
90x75	304	115	81.5	153
110x63	340	122	76	141
110x75	340	122	81.5	138
110x90	340	122	115	197
160x63	384	141	76	169
160x75	384	141	81.5	175
160x90	384	141	115	225
160x110	430	142	122	220
200x63	416	152	76	195
200x75	416	152	81.5	200
200x90	416	152	115	250
200x110	477	155	122	235
200x160	535	155	142	255
225x110	492	166	122	250
225x160	545	166	142	270
250x110	516	180	122	265
250x160	576	180	142	285
250x200	618	180	155	315
315x110	570	198	122	312
315x160	618	198	142	317
315x200	658	198	155	344
355x160	616	206	105	343
355x200	616	206	155	387
355x225	664	206	166	370
355x250	664	206	177	413

**TWO FAUCET COPPER SCREW TEE
A17**



Spec DXRp	H	h	L
63X3/4"	76	52	200
63X1"	76	52	200

CPVC ASTM D2846 STANDARD WATER SUPPLY FITTINGS

TWO FAUCET REDUCER A18

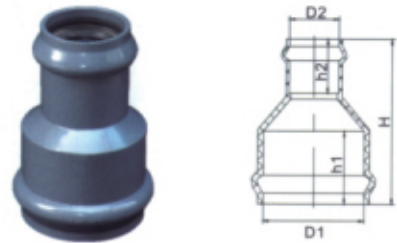

Spec D1xD2	H	h1	h2
90x63	210	115	76
90x75	212	115	81.5
110x63	230	122	76
110x90	255	123	116
160x110	305	140	122
200x110	324	156	122
200x160	325	155	140
225x110	362	160	122
225x160	355	160	140
225x200	355	160	155
250x110	388	175	122
250x160	375	175	140
250x200	372	175	155
250x225	375	175	165
315x160	431	195	140
315x200	430	195	155
315x250	435	195	182
355x200	455	205	155
355x315	438	205	198

FAUCET FLANGE A19



Spec D	d1	d2	H	H1	L	φ	n
63	125	165	88	16	76	17.5	4
75	145	185	92	16	81.5	17.5	4
90	160	200	122	20.5	113.5	17.5	8
110	180	225	148.5	21	124	17.5	8
160	240	285	154	24.5	142	22	8
200	295	336	167.5	27	153	22	8
225	295	340	173.5	31	163	22	8
250	350	395	188	33	177	22	12
315	400	445	215	36.5	199	22	12
355	445-460	505	225	38	209	22	16
400	495-515	565	247.5	41.5	227.5	26	16

INSERT FLANGE A20

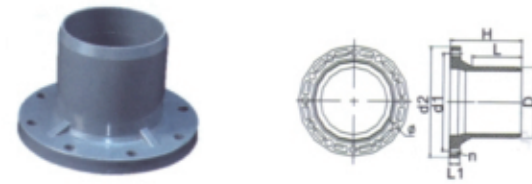

Spec D	d1	d2	H	L	L1	φ	n
63	125	165	110	80	16	17.5	4
75	145	185	113	85	16	17.5	4
90	160	200	153	115	20	17.5	8
110	180	225	167	125	21	17.5	8
160	240	285	196	146	25	22	8
200	295	336	215	166	32	22	8
225	295	340	226.5	170	31	22	8
250	350	395	257.5	180	33	22	12
315	400	445	297.5	200	36.5	22	12
400	495-515	565	303	235	41.5	26	16

TWO FAUCET 22.5° ELBOW A21



Spec D	Z	h
110	152	122
160	166	140.5
200	190	155
225	191	166
250	224	180
315	268	198



**COUPLING
B01**



Size(mm)	1/2"	3/4"	1"	1-1/4"	1-1/2"	2"
D(mm)	15.9	22.2	28.6	34.9	41.3	54.0
L(mm)	12.8	17.9	23.0	28.1	33.2	43.3
Z(mm)	28.6	39.0	49.0	59.2	69.4	90.0

**90 DEG ELBOW
B02**

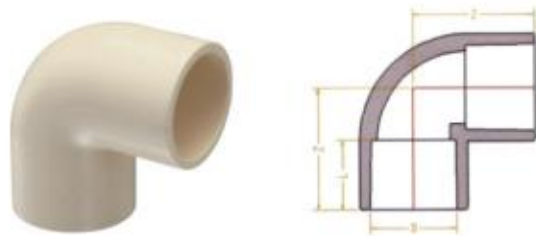

Size(mm)	1/2"	3/4"	1"	1-1/4"	1-1/2"	2"	3/4x1/2
D(mm)	15.9	22.2	28.6	34.9	41.3	54.0	22.2
L(mm)	12.8	17.9	23.0	28.1	33.2	43.3	17.9
Z(mm)	22.8	31.1	39.3	47.5	55.7	72.4	27.0

**TEE
B03**



Size(mm)	1/2"	3/4"	1"	1-1/4"	1-1/2"	2"
D(mm)	15.9	22.2	28.6	34.9	41.3	54.0
L(mm)	12.8	17.9	23.0	28.1	33.2	43.3
Z(mm)	22.8	31.1	39.3	47.5	55.7	72.4

**45DEG ELBOW
B04**



Size(mm)	1/2"	3/4"	1"	1-1/4"	1-1/2"	2"
D(mm)	15.9	22.2	28.6	34.9	41.3	54.0
L(mm)	12.8	17.9	23.0	28.1	33.2	43.3
Z(mm)	17.8	24.2	30.5	37.0	43.2	56.3

**MALE ADAPTER
B05**

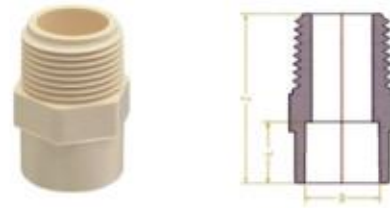

Size(mm)	1/2"	3/4"	1"	1-1/4"	1-1/2"	2"	3/4x1/2
D(mm)	15.9	22.2	28.6	34.9	41.3	54.0	22.2
L(mm)	12.8	17.9	23.0	28.1	33.2	43.3	17.9
Z(mm)	36.0	41.5	50.2	56.0	61.0	73.5	41.5

**REDUCING RING
B06**

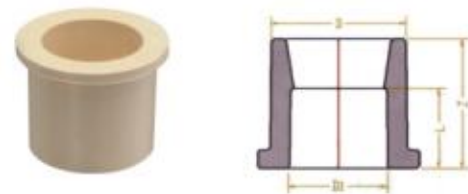

Size(mm)	3/4x1/2"	1x1/2"	1x3/4"	1-1/4x1/2"	1-1/2x3/4"	1-1/2x1"	1-1/2x1/2"	1-1/2x3/4"
D(mm)	22.2	28.6	28.6	34.9	34.9	34.9	41.3	41.3
D1(mm)	15.9	15.9	22.2	15.9	22.2	28.6	15.9	22.2
L(mm)	17.9	23.0	23.0	17.9	23.0	28.1	17.9	23.0
Z(mm)	21.0	26.2	26.2	32.2	32.2	32.2	37.7	37.7

Size(mm)	1-1/2x1"	1-1/2x1-1/4"	2x1/2"	2x3/4"	2x1"	2x1-1/4"	2x1-1/2"
D(mm)	41.3	41.3	54.0	54.0	54.0	54.0	54.0
D1(mm)	28.6	34.9	15.9	22.2	28.6	34.9	41.3
L(mm)	28.1	33.2	17.9	23.0	28.1	33.2	43.3
Z(mm)	37.7	37.7	48.0	48.0	48.0	48.0	48.0

**FEMALE ADAPTER
B07**

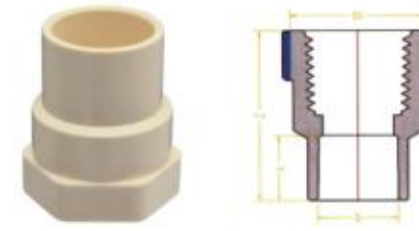

Size(mm)	1/2"	3/4"	1"	1-1/4"	1-1/2"	2"
D(mm)	15.9	22.2	28.6	34.9	41.3	54.0
D1(mm)	27.0	32.5	39.1	49.0	55.0	70.0
L(mm)	12.8	17.9	23.0	28.1	33.2	43.3
Z(mm)	34.0	40.0	49.0	54.0	61.0	73.5

**REDUCING COUPLING
B08**

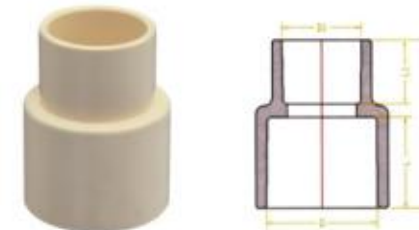

Size(mm)	3/4x1/2"	1x3/4"	1x1/2"	1-1/4x1"	1-1/4x3/4"
D(mm)	22.2	28.6	28.6	34.9	34.9
D1(mm)	15.9	22.2	15.9	28.6	22.2
L(mm)	17.9	23.0	23.0	28.1	28.1
L1(mm)	12.8	17.9	12.8	23.0	17.9
Z(mm)	33.8	44.0	36.0	54.2	49.0

Size(mm)	1-1/2"x1-1/4"	1-1/2"x1"	2"x1-1/2"	2"x1-1/4"
D(mm)	41.3	41.3	54.0	54.0
D1(mm)	34.9	28.6	41.3	34.9
L(mm)	33.2	33.2	43.3	43.3
L1(mm)	28.1	23.0	33.2	28.1
Z(mm)	64.5	59.5	79.5	74.5

**END CAP
B09**



Size(mm)	1/2"	3/4"	1"	1-1/4"	1-1/2"	2"
D(mm)	15.9	22.2	28.6	34.9	41.3	54.0
L(mm)	12.8	17.9	23.0	28.1	33.2	43.3
Z(mm)	18.0	24.0	29.0	35.0	40.0	53.0

**VALVE
B10**



Size(mm)	1/2"	3/4"	1"	1-1/4"	1-1/2"	2"
D(mm)	15.9	22.2	28.6	34.9	41.3	54.0
L(mm)	13.0	18.0	23.0	28.5	33.5	43.5
L1(mm)	68.0	80.0	93.5	104.0	115.0	126.0
Z(mm)	55.0	66.5	81.0	89.0	97.5	120.0

**VALVE-1
B11**



Size(mm)	1/2"	3/4"	1"	1-1/4"	1-1/2"	2"
D(mm)	15.9	22.2	28.6	34.9	41.3	54.0
L(mm)	61.5	74.5	93.0	109.5	129.0	162.0
Z(mm)	50.5	77.5	98.5	99.5	115.0	145.5

**REDUCING TEE
B12**

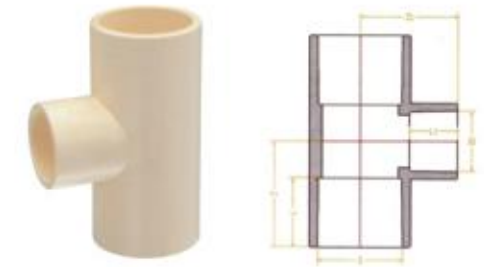

Size(mm)	3/4x1/2"	1x3/4"	1x1/2"	1-1/4x1"	1-1/4x3/4"
D(mm)	22.2	28.6	28.6	34.9	34.9
D1(mm)	15.9	22.2	15.9	28.6	22.2
L(mm)	17.9	23.0	23.0	28.1	28.1
L1(mm)	12.8	17.9	12.8	23.0	17.9
Z(mm)	28.0	36.2	33.0	44.5	40.7
Z1(mm)	26.0	34.5	39.2	42.5	37.9

Size(mm)	1-1/2"x1-1/4"	1-1/2"x1"	2"x1-1/2"	2"x1-1/4"
D(mm)	41.3	41.3	54.0	54.0
D1(mm)	34.9	28.6	41.3	34.9
L(mm)	33.2	33.2	43.3	43.3
L1(mm)	28.1	23.0	33.2	28.1
Z(mm)	52.6	49.5	66.3	63.2
Z1(mm)	50.5	45.5	61.8	56.7

**UNION
B13**

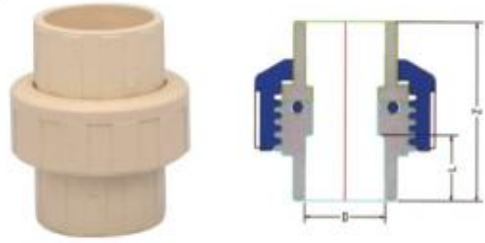

Size(mm)	1/2"	3/4"	1"	1-1/4"	1-1/2"	2"
D(mm)	15.9	22.2	28.6	34.9	41.3	54.0
L(mm)	12.8	17.9	23.0	28.1	33.2	43.3
Z(mm)	35.5	46.5	59.0	72.0	80.0	102.0

**STEP OVER BEND
B14**



Size(mm)	1/2"	3/4"	1"
D(mm)	15.9	22.2	28.6
D1(mm)	28.5	32.5	42.5
L(mm)	152	193	271
L1(mm)	12.8	17.9	23.0
H(mm)	44.4	50.1	69.6

**CLIP
B15**



Size(mm)	1/2"	3/4"	1"	1-1/4"	1-1/2"	2"
D(mm)	15.9	22.2	28.6	34.9	41.3	54.0
L(mm)	37.9	45.7	54.2	70.2	84.0	94.0
Z(mm)	11.9	11.9	12.1	14.3	15.5	15.7
H(mm)	21.5	28.5	35.2	42.2	50.3	64.7

**CLIP
B16**



Size(mm)	1/2"	3/4"	1"
D(mm)	15.9	22.2	28.6
L(mm)	29	39	46.5
H(mm)	21.2	28	34.7

**CROSS TEE
B17**



Size(mm)	1/2"	3/4"	1"	1-1/4"	1-1/2"	2"
D(mm)	15.9	22.2	28.6	34.9	41.3	54.0
L(mm)	12.8	17.9	23.0	28.1	33.2	43.3
Z(mm)	22.8	31.1	39.3	42.2	50.2	72.4

**MALE UNION
B18**

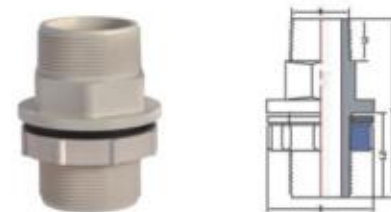

Size(mm)	1/2"	3/4"	1"	1-1/4"	1-1/2"	2"
D(mm)	41.0	46.0	56.5	65.5	71.0	83.0
L(mm)	69.0	76.0	88.0	94.0	102.5	103.5
L1(mm)	15.0	18.0	21.0	24.0	27.0	28.0
L2(mm)	32.0	36.0	41.0	44.0	48.0	50.0
M(mm)	1/2"	3/4"	1"	1-1/4"	1-1/2"	2"

**ELBOW WITH PLATE
B19**



Size(mm)	1/2"
D(mm)	15.9
L(mm)	12.8
L1(mm)	25.5
Z(mm)	16.0
Z1(mm)	27.0
M(mm)	1/2"

**MALL&FEMALE ELBOW(SOCKET)
B20**



Size(mm)	1/2"	3/4"	1"
D(mm)	15.9	22.2	28.6
L(mm)	15.9	22.2	28.6
L1(mm)	13.0	18.0	23.0
Z(mm)	12.5	17.7	22.7
Z1(mm)	22.7	31.1	39.3
M(mm)	25.2	34.1	42.3

**MALE&FEMALE UNION
B21**



Size(mm)	1/2"	3/4"	1"	1-1/4"	1-1/2"	2"
M(mm)	1/2"	3/4"	1"	1-1/4"	1-1/2"	2"
D(mm)	35.5	40	40	52	60	72
L(mm)	50	50	50	63.2	63.2	63.2
L1(mm)	73.8	74.8	78	91.2	92.2	93.2

**COMPRESSION COUPLING
B22**



Size(mm)	1/2"	3/4"	1"
D(mm)	16.5	22.8	29
D1(mm)	36.5	43.3	52
L1(mm)	95	105	115

**MALE COUPLING(COPPER THREAD)
B23**



Size(mm)	1/2"	3/4"	1"	3/4"x1/2"
D(mm)	15.9	22.2	28.6	22.2
D1(mm)	15.9	22.2	15.9	15.9
L(mm)	17.9	23.0	23.0	23.0
L1(mm)	31.0	38.5	46.5	36.5

**FEMALE COUPLING(COPPER THREAD)
B24**



Size(mm)	1/2"	3/4"	1"	3/4"x1/2"	1"x1/2"
D(mm)	15.9	22.2	28.6	22.2	28.6
D1(mm)	15.9	22.2	15.9	15.9	15.9
L(mm)	17.9	23.0	23.0	23.0	23.0
L1(mm)	31.0	38.5	46.5	36.5	41.5

**FEMALE TEE(COPPER THREAD)
B25**



Size(mm)	1/2"x1/2"	3/4"x1/2"	1"x1/2"
D(mm)	15.9	22.2	28.6
L(mm)	12.8	17.9	23.0
Z(mm)	25.0	34.0	36.0
Z1(mm)	29.5	32.7	36.5

**MALE TEE (COPPER THREAD)
B26**

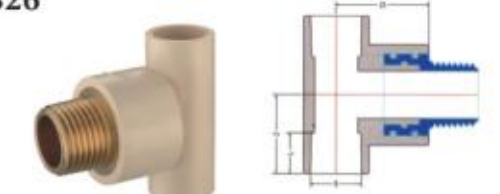

Size(mm)	1/2"x1/2"	3/4"x1/2"	1"x1/2"
D(mm)	15.9	22.2	28.6
Umm	12.8	17.9	23.0
Z(mm)	25.0	34.0	36.0
Z1(mm)	29.5	32.7	36.5

**FEMALE COUPLING (COPPER THREAD)
B27**

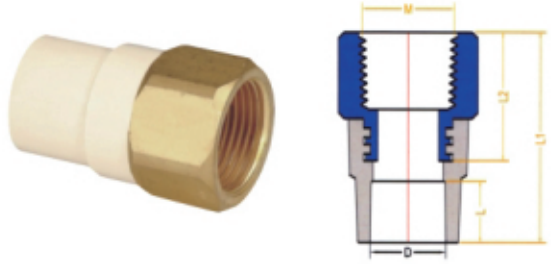

Size(mm)	1/2"	3/4"	1"	1-1/4"	1-1/2"	2"	3/4"x1/2"	1"x3/4"	1-1/4"x1"
D(mm)	15.9	12.8	28.6	34.9	34.9	54.0	22.2	28.6	34.9
L(mm)	12.8	17.9	23.0	28.1	33.2	43.3	17.9	23.0	28.1
L1(mm)	45	50	66	78	83	93	40.0	54.0	70.0
L2(mm)	27.5	28	30	46	46	46.5	27.5	28	30
M(mm)	1/2"	3/4"	1"	1-1/4"	1-1/2"	2"	1/2"	3/4"	1"

**MALE COUPLING (COPPER THREAD)
B28**

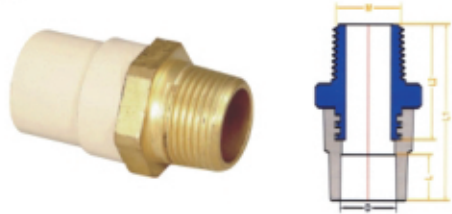

Size(mm)	1/2"	3/4"	1"	1-1/4"	1-1/2"	2"	3/4"x1/2"	1"x3/4"	1-1/4"x1"
D(mm)	15.9	12.8	28.6	34.9	34.9	54.0	22.2	28.6	34.9
L(mm)	12.8	17.9	23.0	28.1	33.2	43.3	17.9	23.0	28.1
L1(mm)	50.5	55	68	79	85	100	53.0	59.0	72.0
L2(mm)	33	33	38	43.8	46.8	54	33	33	38
M(mm)	1/2"	3/4"	1"	1-1/4"	1-1/2"	2"	1/2"	3/4"	1"

**90 DEG FEMALE ELBOW
(COPPER THREAD)
B29**

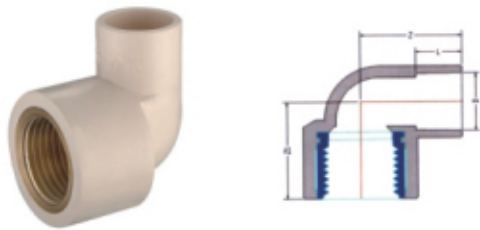

Size(mm)	1/2"x1/2"	3/4"x3/4"	3/4"x1/2"	1"x1/2"	1"x1"
D(mm)	15.9	22.2	22.2	28.6	28.6
L(mm)	12.8	17.9	17.9	23.0	23.0
Z(mm)	25.0	34.0	34.0	36.0	43.5
Z1(mm)	29.5	32.7	32.7	36.5	41.0

**MALE ELBOW(COPPER THREAD)
B30**



Size(mm)	1/2"x1/2"	3/4"x3/4"	3/4"x1/2"	1"x1/2"	1"x1"
D(mm)	15.9	22.2	22.2	28.6	
L(mm)	12.8	17.9	17.9	23.0	
Z(mm)	25.0	34.0	34.0	36.0	
Z1(mm)	29.5	32.7	32.7	36.5	

**ANGLE VALVE
B31**



Size(mm)	1/2"
D(mm)	15.9
L(mm)	27.7
L1(mm)	33.3
Z(mm)	87.0
H(mm)	50.3
M(mm)	1/2"

**ANGLE VALVE
B32**

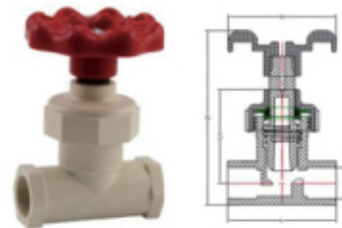

Size(mm)	1/2"
D(mm)	15.9
L(mm)	54.6
L1(mm)	47.5
Z(mm)	88.5
H(mm)	54.0

**ANGLE VALVE
B33**

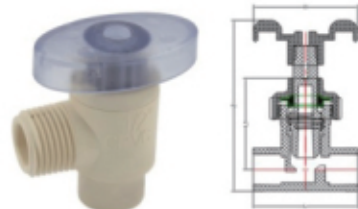

Size(mm)	1/2"
M(mm)	1/2"
L(mm)	16.5
D(mm)	15.72
L1(mm)	13.3
L2(mm)	57.9

CPVC ASTM SCH80 STANDARD WATER SUPPLY FITTINGS

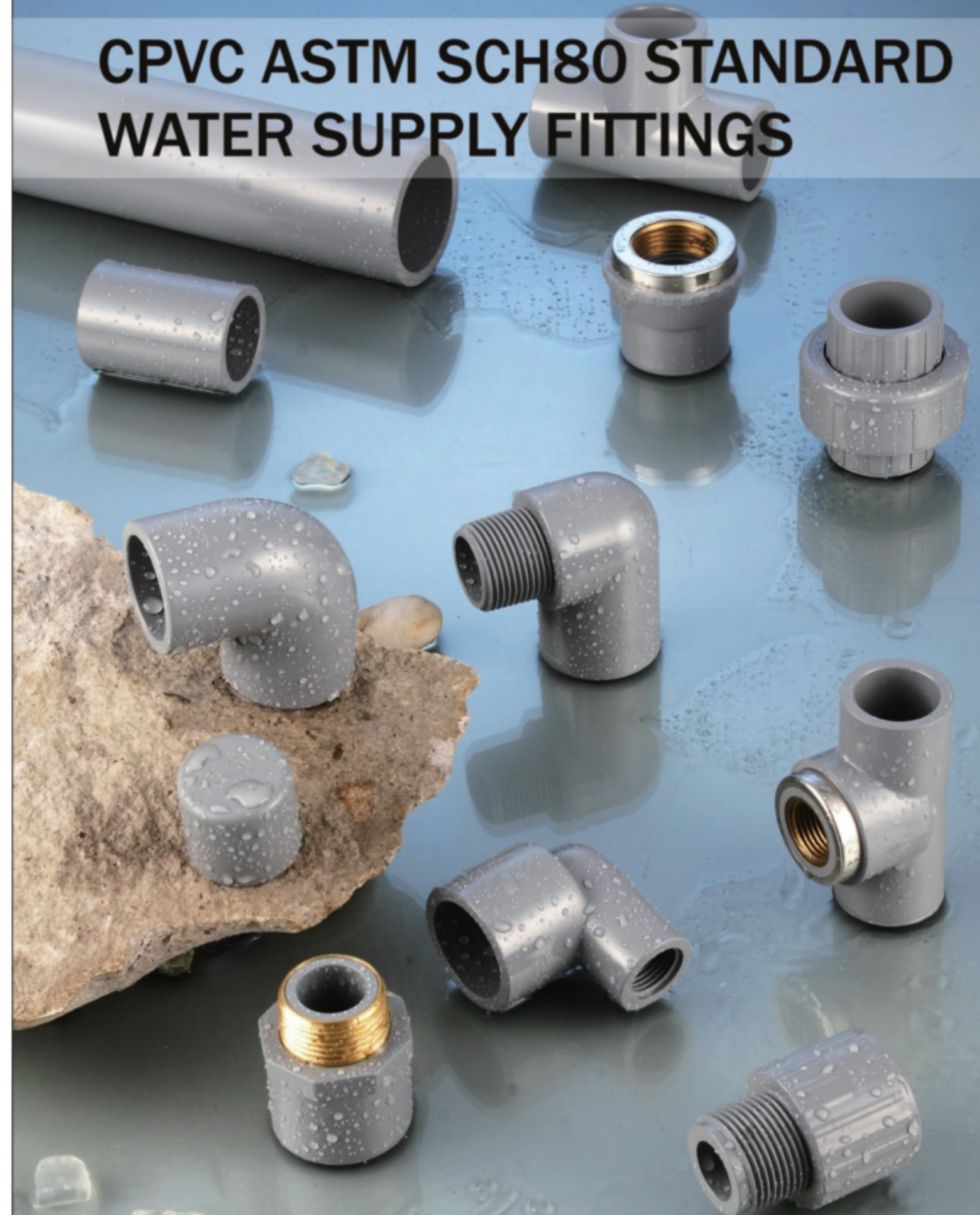

**CPVC ASTM SCH80 PIPES
C01**

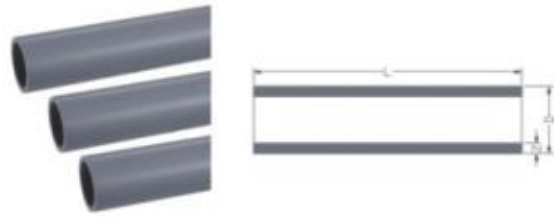

ITEM NO. 5016601 5016602 5016603 5016604 5016605 5016606 5016607 5016608 5016609

Size(mm)	1/2"	3/4"	1"	1-1/4"	1-1/2"	2"	2-1/2"	3"	4"
D(mm)	21.3	26.7	33.4	42.2	48.3	60.3	73	88.9	114.3
L(mm)	4m	4m	4m	4m	4m	4m	4m	4m	4m
Z(mm)	3.7	3.9	4.6	4.9	5.1	5.5	7.1	7.6	8.8

**COUPLING
C02**

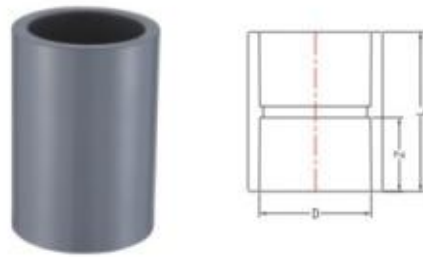

Size(mm)	1/2"	3/4"	1"	1-1/4"	1-1/2"	2"	2-1/2"	3"	4"
D(mm)	21.34	26.67	33.40	42.16	48.26	60.32	73.02	88.90	114.30
L(mm)	36.5	42.5	62.5	68.5	74.5	80.5	97.0	103.0	123.0
Z(mm)	24.0	27.0	30.0	33.0	36.0	39.0	46.0	49.0	59.0

**90 DEG ELBOW
C03**

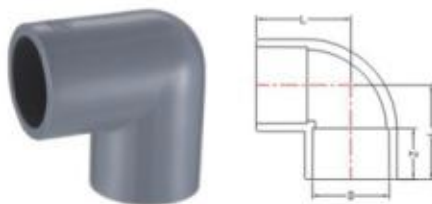

Size(mm)	1/2"	3/4"	1"	1-1/4"	1-1/2"	2"	2-1/2"	3"	4"
D(mm)	21.34	26.67	33.40	42.16	48.26	60.32	73.02	88.90	114.30
L(mm)	36.5	42.5	49.5	56.0	63.0	73.5	86.5	100.0	124.0
Z(mm)	24.0	27.0	30.0	33.0	36.0	39.0	46.0	49.0	59.0

**45 DEG ELBOW
C04**

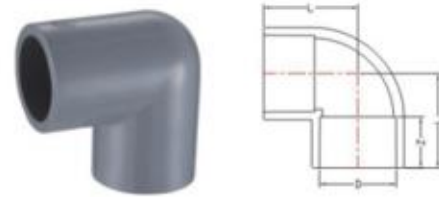

Size(mm)	1/2"	3/4"	1"	1-1/4"	1-1/2"	2"	2-1/2"	3"	4"
D(mm)	21.34	26.67	33.40	42.16	48.26	60.32	73.02	88.90	114.30
L(mm)	30.5	34.5	39.5	45.0	49.0	54.5	66.0	72.0	88.0
Z(mm)	24.0	27.0	30.0	33.0	36.0	39.0	46.0	49.0	59.0

**EQUAL TEE
C05**

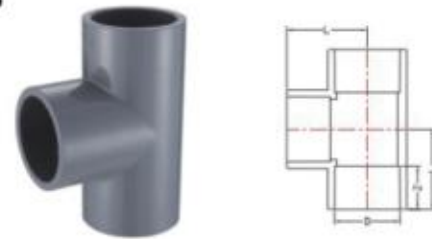

Size(mm)	1/2"	3/4"	1"	1-1/4"	1-1/2"	2"	2-1/2"	3"	4"
D(mm)	21.34	26.67	33.40	42.16	48.26	60.32	73.02	88.90	114.30
L(mm)	36.5	42.5	49.5	56.0	63.0	73.5	86.5	100.0	124.0
Z(mm)	24.0	27.0	30.0	33.0	36.0	39.0	46.0	49.0	59.0

**REDUCING TEE
C06**



Size(mm)	3/4"x1/2"	1"x1/2"	1"x3/4"	1-1/4"x3/4"	1-1/4"x1"	1-1/2"x1"	1-1/2"x1-1/4"	2"x1-1/4"
D(mm)	26.67	33.40	33.40	42.16	42.16	48.26	48.26	60.30
L(mm)	39.5	42.5	45.5	48.5	51.5	56.0	61.0	64.0
Z(mm)	27.0	30.0	30.0	33.0	33.0	36.0	36.0	39.0
D1(mm)	21.34	21.34	26.67	26.67	33.40	33.40	42.16	42.16
L1(mm)	39.0	42.0	45.5	50.0	53.0	57.5	61.0	67.0
Z1(mm)	24.0	24.0	27.0	27.0	30.0	30.0	33.0	33.0

Size(mm)	2"x1-1/2"	2-1/2"x1-1/2"	2-1/2"x2"	3"x2"	3"x2-1/2"	4"x2-1/2"	4"x3"
D(mm)	60.32	73.02	73.02	88.90	88.90	114.30	114.30
L(mm)	64.0	74.0	80.0	83.0	89.5	99.5	107.5
Z(mm)	39.0	46.0	46.0	49.0	49.0	59.0	59.0
D1(mm)	48.26	48.26	60.32	60.32	73.02	73.02	88.90
L1(mm)	70.0	76.5	79.5	87.5	107.0	107.0	110.0
Z1(mm)	36.0	36.0	39.0	39.0	46.0	46.0	49.0

**REDUCING COUPLING
C07**



Size(mm)	3/4"x1/2"	1"x1/2"	1"x3/4"	1-1/4"x3/4"	1-1/4"x1"	1-1/2"x1"	1-1/2"x1-1/4"	2"x1-1/4"
D(mm)	26.67	33.40	33.40	42.16	42.16	48.26	48.26	60.30
L(mm)	60.0	63.0	67.5	75.0	69.0	77.0	83.5	89.0
Z(mm)	27.0	30.0	30.0	33.0	33.0	36.0	36.0	39.0
D1(mm)	21.34	21.34	26.67	26.67	33.40	33.40	42.16	42.16
Z1(mm)	24.0	24.0	27.0	27.0	30.0	30.0	33.0	33.0

Size(mm)	2"x1-1/2"	2-1/2"x1-1/2"	2-1/2"x2"	3"x2"	3"x2-1/2"	4"x2-1/2"	4"x3"
D(mm)	60.32	73.02	73.02	88.90	88.90	114.30	114.30
L(mm)	94.0	99.0	102.0	106.5	115.5	124.5	130.0
Z(mm)	39.0	46.0	46.0	49.0	49.0	59.0	59.0
D1(mm)	48.26	48.26	60.32	60.32	73.02	73.02	88.90
Z1(mm)	36.0	36.0	39.0	39.0	46.0	46.0	49.0

**REDUCING RING
C08**



Size(mm)	3/4"x1/2"	1"x3/4"	1-1/4"x1"	1-1/4"x1-1/4"	1-1/2"x1-1/4"	2"x1-1/2"	2-1/2"x2"	4"x3"
D(mm)	21.34	26.67	33.40	42.16	48.26	60.32	73.02	88.90
L(mm)	34.0	37.0	40.0	43.0	46.0	53.0	61.0	66.0
Z(mm)	24.0	27.0	30.0	33.0	36.0	39.0	46.0	49.0

**END CAP
C09**



Size(mm)	1/2"	3/4"	1"	1-1/4"	1-1/2"	2"	2-1/2"	3"	4"
D(mm)	21.34	26.67	33.40	42.16	48.26	60.32	73.02	88.90	114.30
L(mm)	34.0	37.0	40.0	43.0	46.0	53.0	61.0	66.0	67.5
Z(mm)	24.0	27.0	30.0	33.0	36.0	39.0	46.0	49.0	59.0

**UNION
C10**



Size(mm)	1/2"	3/4"	1"	1-1/4"	1-1/2"	2"
D(mm)	21.34	26.67	33.40	42.16	48.26	60.32
L(mm)	54.0	60.0	68.0	76.0	84.0	93.0
Z(mm)	24.0	27.0	30.0	33.0	36.0	39.0
D1(mm)	48.5	56.2	64.0	75.7	83.4	98.3

**FEMALE ELBOW 90°
C11**

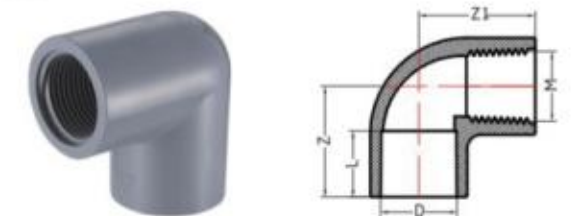

Size(mm)	1/2"	3/4"	1"	1-1/4"	1-1/2"	2"
D(mm)	21.34	26.67	33.40	42.16	48.26	60.32
L(mm)	17.5	18.5	22.5	24.0	28.0	29.5
Z(mm)	31.2	33.5	42.5	48.5	54.2	63.5
Z1(mm)	32.6	40.0	48.0	61.0	61.0	63.2
M(mm)	1/2"	3/4"	1"	1-1/4"	1-1/2"	2"

**REDUCING ELBOW (THREADED)
C12**

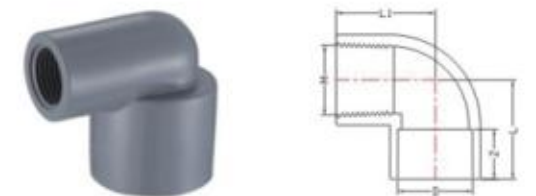

Size(mm)	3/4"x1/2"	1"x1/2"	1"x3/4"
D(mm)	26.67	33.40	33.40
L(mm)	40.0	42.5	45.5
Z(mm)	27.0	30.0	30.0
D1(mm)	21.34	21.34	26.67
L1(mm)	40.0	42.0	45.5
Z1(mm)	24.0	24.0	27.0

**FEMALE ADAPTER
C13**



Size(mm)	1/2"	3/4"	1"	1-1/4"	1-1/2"	2"	2-1/2"	3"	4"
D(mm)	21.34	26.67	33.40	42.16	48.26	60.32	73.02	88.90	114.30
L(mm)	50.5	56.5	62.5	68.5	74.5	80.5	97.0	103.0	123.0
Z(mm)	24.0	27.0	30.0	33.0	36.0	39.0	45.0	49.0	59.0
M(mm)	1/2"	3/4"	1"	1-1/4"	1-1/2"	2"	2-1/2"	3"	4"

**MALE ADAPTER
C14**



Size(mm)	1/2"	3/4"	1"	1-1/4"	1-1/2"	2"	2-1/2"	3"	4"
D(mm)	21.34	26.67	33.40	42.16	48.26	60.32	73.02	88.90	114.30
L(mm)	50.5	56.5	62.5	64.0	69.0	75.5	93.5	99.5	113.5
Z(mm)	24.0	27.0	30.0	33.0	36.0	39.0	46.0	49.0	59.0
M(mm)	1/2"	3/4"	1"	1-1/4"	1-1/2"	2"	2-1/2"	3"	4"

**FEMAL ELBOW
C15**

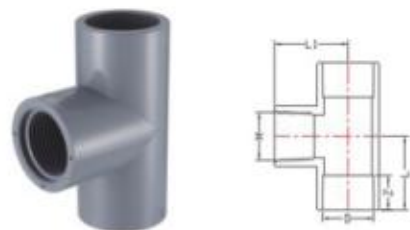

Size(mm)	1/2"	3/4"	1"
D(mm)	29.7	35.4	43.2
L(mm)	36.5	42.0	48.0
Z(mm)	24.0	27.0	30.0
L1(mm)	36.5	42.0	48.0
M(mm)	1/2"	1/2"	3/4"

**FEMALE CAP
C16**

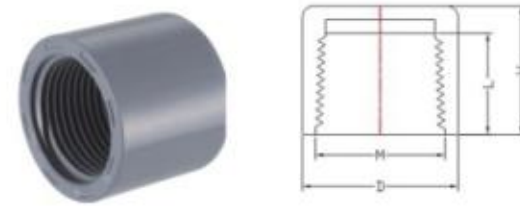

Size(mm)	1/2"	3/4"	1"
D(mm)	29.7	35.4	43.2
L(mm)	30.5	33.5	37.0
Z(mm)	24.0	27.0	30.0
M(mm)	1/2"	3/4"	1"

**MALE ELBOW
C17**

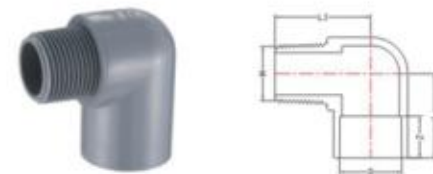

Size(mm)	1/2"	3/4"	1"
D(mm)	29.7	35.4	43.2
L(mm)	36.4	42.7	49.1
Z(mm)	24.0	27.0	30.0
L1(mm)	36.0	42.0	49.0
M(mm)	1/2"	3/4"	1"

**MALE COUPLING (COPPER THREAD)
C18**

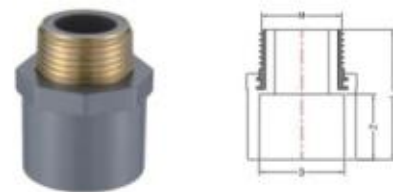

Size(mm)	1/2"	3/4"	1"	1-1/4"	1-1/2"	2"
D(mm)	21.34	26.67	33.40	42.16	48.26	60.32
L(mm)	45.0	51.0	53.0	62.0	66.0	74.0
Z(mm)	24.0	27.0	30.0	33.0	36.0	39.0
M(mm)	1/2"	3/4"	1"	1-1/4"	1-1/2"	2"

**FEMALE COUPLING (COPPER THREAD)
C19**



Size(mm)	1/2"x1/2"	1/2"x3/4"	3/4"x3/4"	3/4"x1/2"	1"x1"	1"x3/4"
D(mm)	21.34	21.34	26.67	26.67	33.40	33.40
L(mm)	19.0	19.0	21.0	21.0	26.0	26.0
Z(mm)	24.0	24.0	27.0	27.0	30.0	30.0
M(mm)	45.0	45.0	45.0	45.0	49.5	49.5

**90DEG FEMALE ELBOW
(COPPER THREAD)
C20**



Size(mm)	1/2"x1/2"	1/2"x3/4"	3/4"x3/4"	3/4"x1/2"
D(mm)	21.34	21.34	26.67	26.67
L(mm)	29.0	29.0	31.0	31.0
Z(mm)	24.0	24.0	27.0	27.0
D1(mm)	42.5	42.5	42.5	42.5
L1(mm)	34.0	34.0	36.5	36.5

**FEMALE TEE (COPPER THREAD)
C21**

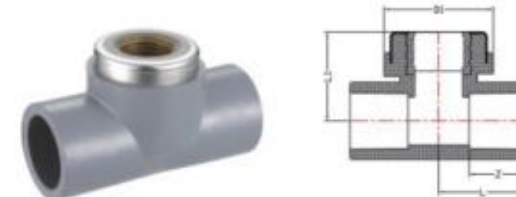

Size(mm)	1/2"x1/2"	1/2"x3/4"	3/4"x3/4"	3/4"x1/2"
D(mm)	21.34	21.34	26.67	26.67
L(mm)	34.0	34.0	37.0	37.0
Z(mm)	24.0	24.0	27.0	27.0
D1(mm)	42.5	42.5	42.5	42.5
L1(mm)	34.0	34.0	36.5	36.5

**CPVC VALVE
C22**

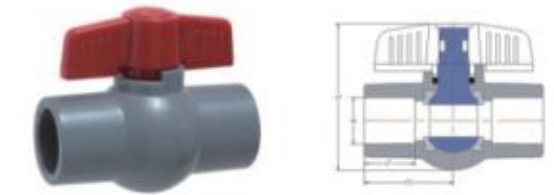

Size(mm)	1/2"	3/4"	1"	1-1/4"	1-1/2"	2"
D(mm)	21.4	26.7	33.4	42.2	48.3	60.3
L(mm)	19.5	22.5	26.5	28.6	32.0	35.5
Z(mm)	38.1	43.8	49.8	59.0	63.5	74.0
M(mm)	66.0	77.0	87.0	99.0	74.0	130.0

**THE DOUBLE COPPER ELBOW
C23**

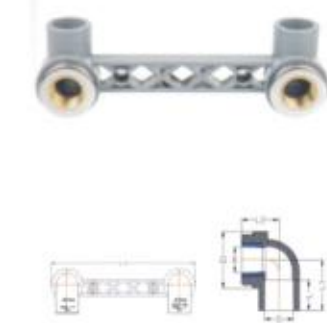

Size(mm)	1/2"
D(mm)	1.34
D1(mm)	42.0
L(mm)	22.5
L1(mm)	37.5
L2(mm)	27.8
L3(mm)	190.5
M(mm)	1/2"

PVC-U PRESSURE FITTING(SCH40)



COUPLING D01

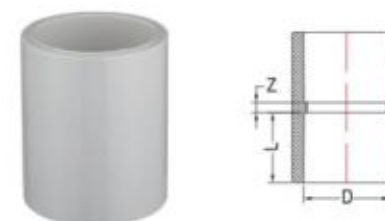

Size(mm)	1/2"	3/4"	1"	1-1/4"	1-1/2"	2"	2-1/2"	3"	4"
D(mm)	21.34	26.67	33.40	42.16	48.26	60.32	73.02	88.90	114.30
L(mm)	17.5	18.5	22.5	24.0	28.0	29.5	44.5	48.0	51.0
Z(mm)	2.5	3.0	3.5	3.5	3.5	5.0	5.0	5.5	6.0

90 DEG ELBOW D02



Size(mm)	1/2"	3/4"	1"	1-1/4"	1-1/2"	2"	2-1/2"	3"	4"
D(mm)	21.34	26.67	33.40	42.16	48.26	60.32	73.02	88.90	114.30
L(mm)	17.5	18.5	22.5	24.0	28.0	29.5	44.5	48.0	51.0
Z(mm)	30.0	33.5	41.5	47.5	54.5	63.5	85.0	96.5	113.0

45 DEG ELBOW D03

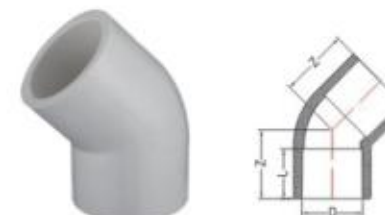

Size(mm)	1/2"	3/4"	1"	1-1/4"	1-1/2"	2"	2-1/2"	3"	4"
D(mm)	21.34	26.67	33.40	42.16	48.26	60.32	73.02	88.90	114.30
L(mm)	17.5	18.5	22.5	24.0	28.0	29.5	44.5	48.0	51.0
Z(mm)	24.0	26.0	32.0	35.5	41.0	46.5	64.0	71.0	80.0

TEE D04

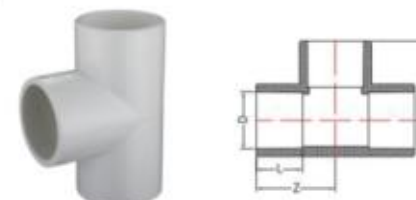

Size(mm)	1/2"	3/4"	1"	1-1/4"	1-1/2"	2"	2-1/2"	3"	4"
D(mm)	21.34	26.67	33.40	42.16	48.26	60.32	73.02	88.90	114.30
L(mm)	17.5	18.5	22.5	24.0	28.0	29.5	44.5	48.0	51.0
Z(mm)	30.0	22.5	41.5	47.5	54.5	63.5	85.0	96.5	113.0
Z1(mm)	30.0	24.0	41.5	47.5	54.5	63.5	85.0	96.5	113.0

REDUCING TEE D05

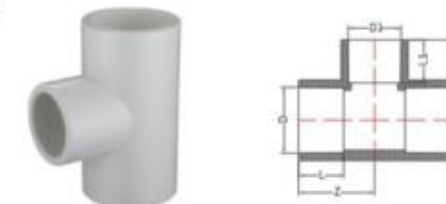

Size(mm)	3/4"x1/2"	1"x1/2"	1"x3/4"	1-1/4"x3/4"	1-1/4"x1"	1-1/2"x1"	1-1/2"x1-1/4"	2"x1-1/4"
D(mm)	26.67	33.40	33.40	42.16	42.16	48.26	48.26	60.30
L(mm)	21.34	21.34	26.67	26.67	33.40	33.40	42.16	42.16
Z(mm)	18.5	22.5	22.5	24.0	24.0	28.0	28.0	29.5
D1(mm)	17.5	17.5	18.5	18.5	22.5	22.5	24.0	24.0
L1(mm)	30.8	35.3	38.0	39.8	43.2	47.2	51.5	54.6
Z1(mm)	32.7	36.5	37.5	42.0	46.0	49.0	50.7	58.2

Size(mm)	2"x1-1/2"	2-1/2"x1-1/2"	2-1/2"x2"	3"x2"	3"x2-1/2"	4"x2-1/2"	4"x3"
D(mm)	60.32	73.02	73.02	88.90	88.90	114.30	114.30
L(mm)	48.26	48.26	60.32	60.32	73.02	73.02	88.90
Z(mm)	29.5	44.5	44.5	48.0	48.0	51.0	51.0
D1(mm)	28.0	28.0	29.5	29.5	44.5	44.5	48.0
L1(mm)	57.6	72.6	78.6	82.5	88.5	92.0	100.0
Z1(mm)	62.1	68.3	70.0	78.2	93.2	106.5	109.5

REDUCING COUPLING D06

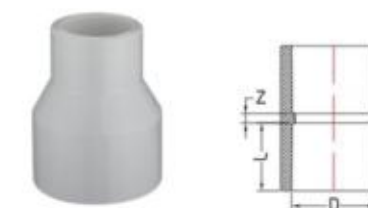

Size(mm)	3/4"x1/2"	1"x1/2"	1"x3/4"	1-1/4"x3/4"	1-1/4"x1"	1-1/2"x1"	1-1/2"x1-1/4"	2"x1-1/4"
D(mm)	26.7	33.40	33.40	42.16	42.16	48.26	48.26	60.30
D1(mm)	21.34	21.34	26.67	26.67	33.40	33.40	42.16	42.16
D2(mm)	18.5	22.5	22.5	24.0	24.0	28.0	28.0	29.5
L(mm)	17.5	17.5	18.5	18.5	22.5	22.5	24.0	24.0
Z(mm)	45.0	50.0	50.0	55.0	60.0	65.0	67.0	70.0

Size(mm)	2"x1-1/2"	2-1/2"x1-1/2"	2-1/2"x2"	3"x2"	3"x2-1/2"	4"x2-1/2"	4"x3"
D(mm)	60.32	73.02	73.02	88.90	88.90	114.30	114.30
D1(mm)	48.26	48.26	60.32	60.32	73.02	73.02	88.90
D2(mm)	29.5	44.5	44.5	48.0	48.0	51.0	124.0
L(mm)	28.0	28.0	29.5	29.5	44.5	44.5	48.0
Z(mm)	72.0	90.0	92.0	97.0	110.0	125.0	130.0

CAP D07



Size(mm)	1/2"	3/4"	1"	1-1/4"	1-1/2"	2"	2-1/2"	3"	4"
D(mm)	21.34	26.67	33.40	42.16	48.26	60.32	73.02	88.90	114.30
L(mm)	17.5	18.5	22.5	24.0	28.0	29.5	44.5	48.0	51.0
Z(mm)	2.5	3.0	3.5	3.5	3.5	5.0	5.0	5.5	6.0

REDUCING BUSHING

D08



Size(mm)	3/4"x1/2"	1"x1/2"	1"x3/4"	1-1/4"x1"	1-1/2"x1"	1-1/2"x1-1/4"
D(mm)	26.67	33.40	33.40	42.16	48.26	48.26
D1(mm)	21.34	21.34	26.67	33.40	33.40	42.16
D2(mm)	33.0	40.0	40.0	47.8	54.0	54.0
L(mm)	17.5	17.5	18.5	22.5	22.5	24.0
Z(mm)	27.5	28.5	28.5	31.5	34.0	36.0

Size(mm)	2"x1"	2"x1-1/2"	2-1/2"x2"	3"x2-1/2"	4"x3"
D(mm)	60.32	60.32	73.02	88.90	114.30
D1(mm)	33.40	48.26	60.32	73.02	88.90
D2(mm)	66.5	66.5	82.0	97.5	124.0
L(mm)	22.5	28.0	29.5	44.5	48.0
Z(mm)	36.5	39.0	53.5	57.0	61.0

COMPRESSION COUPLING

D09



Size(mm)	1/2"	3/4"	1"	1-1/4"	1-1/2"	2"	2-1/2"	3"	4"
D(mm)	21.34	26.67	33.40	42.16	48.26	60.32	73.02	88.90	114.30
D1(mm)	46.5	53.0	50.0	71.0	79.0	93.0	109.5	122.0	158.0
Z(mm)	108.0	116.0	126.0	146.0	163.0	188.0	213.0	252.0	305.0

UNION

D10



Size(mm)	1/2"	3/4"	1"	1-1/4"	1-1/2"	2"
D(mm)	27.0	32.5	39.0	54.0	60.0	76.0
D1(mm)	51.6	65.8	74.0	87.0	102.5	120.0
L(mm)	17.5	18.5	22.5	24.0	28.0	29.5
Z(mm)	54.5	58.2	68.8	75.3	83.0	103.2

CAP

D11

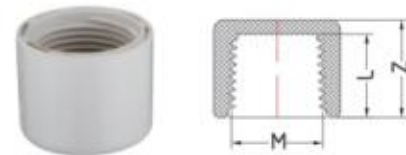

Size(mm)	1/2"	3/4"	1"
D(mm)	1/2"	3/4"	1"
L(mm)	18.0	21.0	21.0
Z(mm)	21.0	26.0	26.0

90 DEG FEMALE ELBOW

D12



Size(mm)	1/2"	3/4"	1"	1-1/4"	1-1/2"	2"
D(mm)	21.34	26.67	33.40	42.16	48.26	60.32
L(mm)	17.5	18.5	22.5	24.0	28.0	29.5
Z(mm)	31.2	33.5	42.5	48.5	54.2	63.5
Z1(mm)	32.8	40.0	48.0	61.0	61.0	63.2
M(mm)	1/2"	3/4"	1"	1-1/4"	1-1/2"	2"

REDUCING 90 DEG FEMALE ELBOW

D13



Size(mm)	1/2"x3/4"	3/4"x1/2"	1"x1/2"	1"x3/4"
D(mm)	21.34	26.67	33.40	33.40
L(mm)	17.5	18.5	22.5	22.5
Z(mm)	37.5	44.5	51.5	51.5
Z1(mm)	38.5	38.5	38.5	38.5
M(mm)	3/4"	1/2"	1/2"	3/4"

FEMALE ADAPTER

D14



Size(mm)	1/2"	3/4"	1"	1-1/4"	1-1/2"
D(mm)	21.34	26.67	33.40	42.16	48.26
L(mm)	17.5	18.5	22.5	24.0	28.0
Z(mm)	41.5	43.0	55.0	55.0	61.5
M(mm)	1/2"	3/4"	1"	1-1/4"	1-1/2"

Size(mm)	2"	2-1/2"	3"	4"	3/4"x1/2"
D(mm)	60.32	73.02	88.90	114.30	26.67
L(mm)	29.5	44.5	48.0	51.0	18.5
Z(mm)	62.0	91.0	95.0	100.0	41.0
M(mm)	2"	2-1/2"	3"	4"	1/2"

MALE ADAPTER

D15



Size(mm)	1/2"	3/4"	1"	1-1/4"	1-1/2"	2"	2-1/2"	3"	4"
D(mm)	21.34	26.67	33.40	42.16	48.26	60.32	73.02	88.90	114.30
L(mm)	17.5	18.5	22.5	24.0	28.0	29.5	44.5	48.0	51.0
Z(mm)	41.5	43.0	55.0	55.0	61.5	62.0	91.0	95.0	100.0
M(mm)	1/2"	3/4"	1"	1-1/4"	1-1/2"	2"	2-1/2"	3"	4"

FEMALE TEE

D16

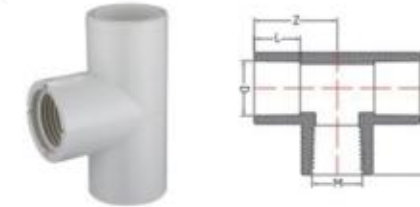

Size(mm)	1/2"	3/4"	1"
D(mm)	21.34	26.67	33.40
L(mm)	17.5	18.5	22.5
Z(mm)	32.5	42.0	48.3
Z1(mm)	34.0	35.5	48.2
M(mm)	1/2"	3/4"	1"

MALE THREAD PLUG

D17



Size(mm)	1/2"	3/4"	1"	1-1/4"	1-1/2"	2"	2-1/2"	3"	4"
D(mm)	27.0	32.5	39.0	54.0	60.0	76.0	83.5	103.5	133.0
L(mm)	23.8	25.4	31.8	32.0	32.0	34.0	49.0	51.0	54.5
Z(mm)	5.0	6.0	6.0	6.0	6.0	6.0	8.0	10.0	12.0
M(mm)	1/2"	3/4"	1"	1-1/4"	1-1/2"	2"	2-1/2"	3"	4"

FEMALE ELBOW

D18



Size(mm)	1/2"	3/4"	1"
D(mm)	21.34	26.67	33.40
L(mm)	17.5	18.5	22.5
Z(mm)	35.0	38.5	46.0
Z1(mm)	36.5	39.5	52.0
M(mm)	1/2"	3/4"	1"

MALE & FEMALE ELBOW(SOCKET)

D19

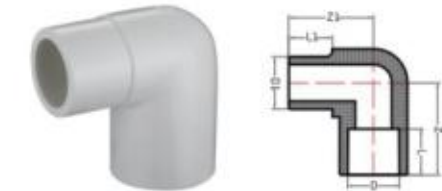

Size(mm)	1/2"	3/4"	1"
D(mm)	21.34	26.67	33.40
D1(mm)	21.34	26.67	33.40
L(mm)	17.5	18.5	22.5
L1(mm)	17.5	18.5	22.5
Z(mm)	38.0	40.5	48.0
Z1(mm)	35.0	39.5	46.5

MALE & FEMALE ELBOW

D20



Size(mm)	1/2"	3/4"	1"
M(mm)	1/2"	3/4"	1"
M1(mm)	1/2"	3/4"	1"
L(mm)	17.8	22.5	28.0
L1(mm)	18.2	22.8	28.0
Zmm)	29.3	36.9	46.0
Z1(mm)	33.2	41.8	52.0

REDUCING ELBOW

D21



Size(mm)	3/4"x1/2"	1"x1/2"	1"x3/4"
M(mm)	26.67	33.40	33.40
M1(mm)	21.37	21.34	26.67
L(mm)	18.5	22.5	22.5
L1(mm)	17.5	17.5	18.5
Zmm)	33.0	38.0	40.0
Z1(mm)	32.0	34.0	36.0

PVC-U PRESSURE FITTINGS(SCH80)



COUPLING E01



Size(mm)	1/2"	3/4"	1"	1-1/4"	1-1/2"	2"	2-1/2"	3"	4"
D(mm)	21.34	26.67	33.40	42.16	48.26	60.32	73.02	88.90	114.30
L(mm)	50.2	56.5	62.5	68.5	74.5	80.5	97.0	103.0	123.0
Z(mm)	24.0	27.0	30.0	33.0	36.0	39.0	46.0	49.0	59.0

90 DEG ELBOW E02



Size(mm)	1/2"	3/4"	1"	1-1/4"	1-1/2"	2"	2-1/2"	3"	4"
D(mm)	21.34	26.67	33.40	42.16	48.26	60.32	73.02	88.90	114.30
L(mm)	36.5	42.5	49.5	56.0	63.0	73.5	86.5	100.0	124.0
Z(mm)	24.0	27.0	30.0	33.0	36.0	39.0	46.0	49.0	59.0

45 DEG ELBOW E03



Size(mm)	1/2"	3/4"	1"	1-1/4"	1-1/2"	2"	2-1/2"	3"	4"
D(mm)	21.34	26.67	33.40	42.16	48.26	60.32	73.02	88.90	114.30
L(mm)	30.5	34.5	39.5	45.0	49.0	54.5	66.0	72.0	88.0
Z(mm)	24.0	27.0	30.0	33.0	36.0	39.0	46.0	49.0	59.0

EQUAL TEE E04



Size(mm)	1/2"	3/4"	1"	1-1/4"	1-1/2"	2"	2-1/2"	3"	4"
D(mm)	21.34	26.67	33.40	42.16	48.26	60.32	73.02	88.90	114.30
L(mm)	36.5	42.5	49.5	56.0	63.0	73.5	86.5	100.0	124.0
Z(mm)	24.0	27.0	30.0	33.0	36.0	39.0	46.0	49.0	59.0

REDUCING TEE E05

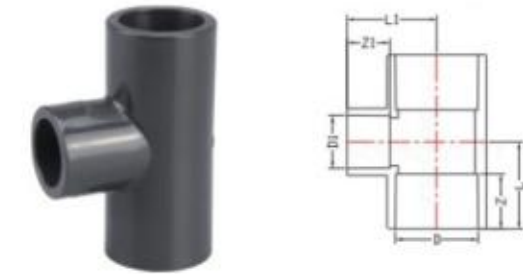

Size(mm)	3/4"x1/2"	1"x1/2"	1"x3/4"	1-1/4"x3/4"	1-1/4"x1"	1-1/2"x1"	1-1/2"x1-1/4"	2"x1-1/4"
D(mm)	26.67	33.40	33.40	42.16	42.16	48.26	48.26	60.30
L(mm)	39.5	42.5	45.5	48.5	51.5	56.0	61.0	64.0
Z(mm)	27.0	30.0	30.0	33.0	33.0	36.0	36.0	39.0
D1(mm)	21.34	21.34	26.67	26.67	33.40	33.40	42.16	42.16
L1(mm)	39.0	42.0	45.5	50.0	53.0	57.5	61.0	67.0
Z1(mm)	24.0	24.0	27.0	27.0	30.0	30.0	33.0	33.0

Size(mm)	2"x1-1/2"	2-1/2"x1-1/2"	2-1/2"x2"	3"x2"	3"x2-1/2"	4"x2-1/2"	4"x3"
D(mm)	60.32	73.02	73.02	88.90	88.9	114.30	114.30
L(mm)	64.0	74.0	80.0	83.0	89.5	99.5	107.5
Z(mm)	39.0	46.0	46.0	49.0	49.0	59.0	59.0
D1(mm)	48.26	48.26	60.32	60.32	73.02	73.02	88.9
L1(mm)	70.0	76.5	79.5	87.5	107.0	107.0	110.0
Z1(mm)	36.0	36.0	39.0	39.0	46.0	46.0	49.0

REDUCING COUPLING E06

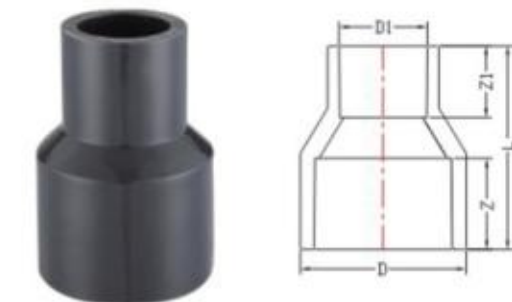

Size(mm)	3/4"x1/2"	1"x1/2"	1"x3/4"	1-1/4"x3/4"	1-1/4"x1"	1-1/2"x1"	1-1/2"x1-1/4"	2"x1-1/4"
D(mm)	26.67	33.40	33.40	42.16	42.16	48.26	48.26	60.30
L(mm)	60.0	63.0	67.5	75.0	69.0	77.0	83.5	89.0
Z(mm)	27.0	30.0	33.0	33.0	33.0	36.0	36.0	39.0
D1(mm)	21.34	21.34	26.67	26.67	33.40	33.40	42.16	42.16
Z1(mm)	24.0	24.0	27.0	27.0	30.0	30.0	33.0	33.0

Size(mm)	2"x1-1/2"	2-1/2"x1-1/2"	2-1/2"x2"	3"x2"	3"x2-1/2"	4"x2-1/2"	4"x3"
D(mm)	60.32	73.02	73.02	88.90	88.90	114.30	114.30
L(mm)	94.0	99.0	102.0	106.5	115.5	124.5	130.0
Z(mm)	39.0	46.0	46.0	49.0	49.0	59.0	59.0
D1(mm)	49.26	48.26	60.32	60.32	73.02	73.02	88.90
Z1(mm)	36.0	36.0	39.0	39.0	46.0	46.0	49.0

**REDUCING RING
E07**

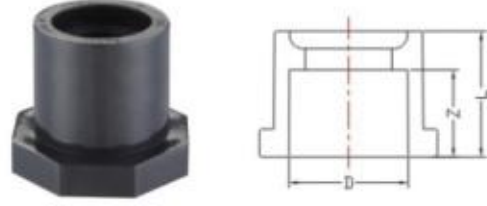

Size(mm)	3/4"x1/2"	1"x3/4"	1-1/4"x1"	1-1/4"x1"	1-1/2"x1-1/4"	2"x1-1/2"	2-1/2"x2"	4"x3"
D(mm)	21.34	26.67	33.40	42.16	48.26	60.32	73.02	88.90
L(mm)	34.0	37.0	40.0	43.0	46.0	53.0	61.0	66.0
Z(mm)	24.0	27.0	30.0	33.0	36.0	39.0	46.0	49.0

**END CAP
E08**



Size(mm)	1/2"	3/4"	1"	1-1/4"	1-1/2"	2"	2-1/2"	3"	4"
D(mm)	21.34	26.67	33.40	42.16	48.26	60.32	73.02	88.90	114.30
L(mm)	34.0	37.0	40.0	43.0	46.0	53.0	61.0	66.0	67.5
Z(mm)	24.0	27.0	30.0	33.0	36.0	39.0	46.0	49.0	59.0

**UNION
E09**



Size(mm)	1/2"	3/4"	1"	1-1/4"	1-1/2"	2"
D(mm)	21.34	26.67	33.40	42.16	48.26	60.32
L(mm)	54.0	60.0	68.0	76.0	84.0	93.0
Z(mm)	24.0	27.0	30.0	33.0	36.0	39.0
D1(mm)	48.5	56.2	64.0	75.7	83.4	98.3

**FEMALE ELBOW
E10**



Size(mm)	1/2"	3/4"	1"
D(mm)	29.7	35.4	43.2
L(mm)	36.4	42.7	49.1
Z(mm)	24.0	27.0	30.0
L1(mm)	36.4	42.7	49.1
M(mm)	1/2"	3/4"	1"

**REDUCING ELBOW (THREADED)
E11**



Size(mm)	3/4x1/2"	1"x1/2"	1"x3/4"
D(mm)	26.67	33.40	33.40
L(mm)	40.0	42.5	45.5
Z(mm)	27.0	30.0	30.0
D1(mm)	21.34	21.34	26.67
L1(mm)	40.0	42.5	45.5
Z1(mm)	24.0	24.0	27.0

**MALE ELBOW 90°
E12**



Size(mm)	1/2"	3/4"	1"
D(mm)	29.7	35.4	43.2
L(mm)	36.4	42.7	49.1
Z(mm)	24.0	27.0	30.0
L1(mm)	36.0	42.0	49.0
M(mm)	1/2"	3/4"	1"

**FEMALE ADAPTER
E13**



Size(mm)	1/2"	3/4"	1"	1-1/4"	1-1/2"	2"	2-1/2"	3"	4"
D(mm)	21.34	26.67	33.40	42.16	48.26	60.32	73.02	88.90	114.30
L(mm)	50.5	56.5	62.5	68.5	74.5	80.5	97.0	103.0	123.0
Z(mm)	24.0	27.0	30.0	33.0	36.0	39.0	45.0	49.0	59.0
M(mm)	1/2"	3/4"	1"	1-1/4"	1-1/2"	2"	2-1/2"	3"	4"

**MALE ADAPTER
E14**



Size(mm)	1/2"	3/4"	1"	1-1/4"	1-1/2"	2"	2-1/2"	3"	4"
D(mm)	21.34	26.67	33.40	42.16	48.26	60.32	73.02	88.90	114.30
L(mm)	43.5	53.0	58.5	64.0	69.0	75.5	93.5	99.5	113.5
Z(mm)	24.0	27.0	30.0	33.0	36.0	39.0	45.0	49.0	59.0
M(mm)	1/2"	3/4"	1"	1-1/4"	1-1/2"	2"	2-1/2"	3"	4"

**FEMALE TEE
E15**



Size(mm)	3/4x1/2"	1"x1/2"	1"x3/4"
D(mm)	29.7	35.4	43.2
L(mm)	36.5	42.0	48.0
Z(mm)	24.0	27.0	30.0
L1(mm)	36.5	42.0	48.0
M(mm)	1/2"	1/2"	3/4"

**FEMALE CAP
E16**

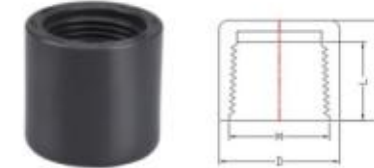

Size(mm)	1/2"	3/4"	1"
D(mm)	29.7	35.4	43.2
L(mm)	30.5	33.5	37.0
Z(mm)	24.0	27.0	30.0
M(mm)	1/2"	3/4"	1"

**MALE COUPLING (COPPER THREAD)
E17**

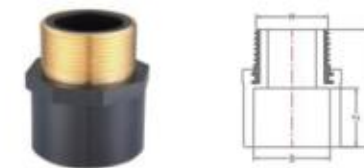

Size(mm)	1/2"	3/4"	1"	1-1/4"	1-1/2"	2"
D(mm)	21.34	26.67	33.40	42.16	48.26	60.32
L(mm)	45.0	51.0	53.0	62.0	66.0	74.0
Z(mm)	24.0	27.0	30.0	33.0	36.0	39.0
M(mm)	1/2"	3/4"	1"	1-1/4"	1-1/2"	2"

**FEMALE COUPLING (COPPER THREAD)
E18**

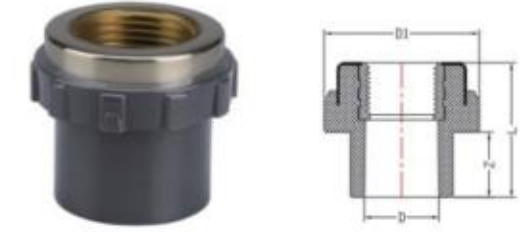

Size(mm)	1/2"x1/2"	1/2"x3/4"	3/4"x3/4"	3/4"x1/2"	1"x1"	1"x3/4"
D(mm)	21.34	21.34	26.67	26.67	33.40	33.40
L(mm)	19.0	19.0	21.0	21.0	26.0	26.0
Z(mm)	24.0	24.0	27.0	27.0	30.0	30.0
M(mm)	45.0	45.0	45.0	45.0	49.5	49.5

**90DEG FEMALE ELBOW
(COPPER THREAD)
E19**

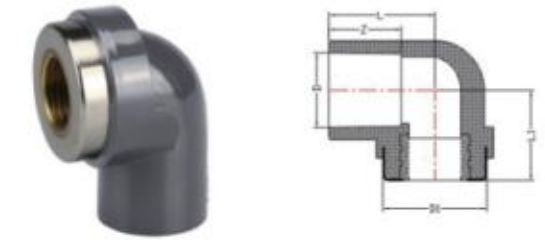

Size(mm)	1/2"x1/2"	1/2"x3/4"	3/4"x3/4"	3/4"x1/2"
D(mm)	21.34	21.34	26.67	26.67
L(mm)	29.0	29.0	31.0	31.0
Z(mm)	24.0	24.0	27.0	27.0
D1(mm)	42.5	42.5	42.5	42.5
L1(mm)	28.0	28.0	29.5	29.5

**FEMALE TEE (COPPER THREAD)
E20**



Size(mm)	1/2"x1/2"	1/2"x3/4"	3/4"x3/4"	3/4"x1/2"
D(mm)	21.34	21.34	26.67	26.67
L(mm)	34.0	34.0	37.0	37.0
Z(mm)	24.0	24.0	27.0	27.0
D1(mm)	42.5	42.5	42.5	42.5
L1(mm)	34.0	34.0	36.5	36.5

PVC-U NBR 5648 WATER SUPPLY PIPE FITTINGS



ADAPTER G01



Size(mm)	20	25	32	40	50	60	63	75	90	110
D(mm)	20	25	32	40	50	60	63	75	90	110
Z(mm)	3	3	3	4	4	4	4	5	6	6
L(mm)	16	18	22.5	26	31	37.5	37.5	44	51	61
L1(mm)	35.5	40	48	56.5	65.5	79	79	93	108	128

REDUCING COUPLING G02

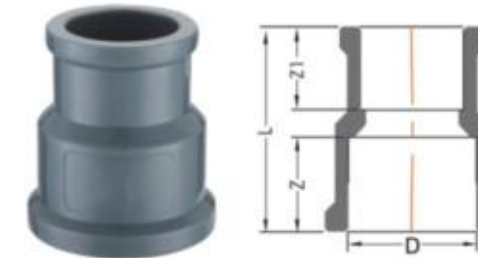

Size(mm)	25x20	32x20	32x25	40x25	40x32	50x32	50x40	60x40	60x50
Z(mm)	18	22.5	22.5	26	26	31	31	37	37
Z1(mm)	16	16	18	18.5	22.5	22.5	26	26	31
L(mm)	40	46	46	55	55	65	65	79	79

Size(mm)	63x40	63x50	75x50	75x60	75x63	90x60	90x63	90x75	110x75	110x90
Z(mm)	37.5	37.5	44	44	44	51	51	51	61	61
Z1(mm)	26	31	31	37	37.5	37	37.5	44	44	51
L(mm)	79	79	93	93	93	108	108	108	128	128

ELBOW G03



Size(mm)	20	25	32	40	50	60	63	75	90	110
D(mm)	20	25	32	40	50	60	63	75	90	110
Z(mm)	16	18	22.5	26	31	37.5	37.5	44	51	61
L(mm)	27	32	40	47	57.5	39.5	39.5	83.5	99	124

REDUCING ELBOW G04



Size(mm)	25x20	32x20	32x25	40x25	40x32
D(mm)	25	32	32	40	40
Z(mm)	18	22.5	22.5	26	26
L(mm)	29.5	34	36.5	41	45
L1(mm)	29	34	36	39.5	43.4

TEE G05



Size(mm)	20	25	32	40	50	60	63	75	90	110
D(mm)	20	25	32	40	50	60	63	75	90	110
Z(mm)	16	18	22.5	26	31	37.5	37.5	44	51	61
L(mm)	27	32	40	47	57.5	39.5	39.5	83.5	99	124

REDUCING TEE G06



Size(mm)	25x20	32x20	32x25	40x25	40x32	50x32	50x40	60x40	60x50
D(mm)	25	32	32	40	40	50	50	60	60
Z(mm)	18	22.5	22.5	26	26	31	31	37	37
L(mm)	29.5	34	36.5	41	45	50.5	53	58.5	63
L1(mm)	29	34	36	39.5	43.5	48	51.5	58.5	63

Size(mm)	63x40	63x50	75x50	75x60	75x63	90x60	90x63	90x75	110x75	110x90
D(mm)	63	63	75	75	75	90	90	90	110	110
Z(mm)	37.5	37.5	44	44	44	51	51	51	61	61
L(mm)	58.5	63	71	77.5	77.5	85.5	85.5	91.5	103.5	111
L1(mm)	58.5	63	70	77	77	85	85	92	102	109

FEMALE ELBOW

G07



Size(mm)	20x1/2"	25x3/4"	32x1"
D(mm)	20	25	32
Z(mm)	16	18	22.5
L(mm)	27	32	40
L1(mm)	29	34	41

FEMALE COUPLING

G08

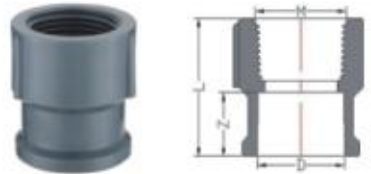

Size(mm)	20x1/2"	25x3/4"	32x1	40x1-1/4"	50x1-1/2"	60x2"
D(mm)	20	25	32	40	50	60
Z(mm)	16	18	22.5	26	31	37.5
L(mm)	37.5	40	48	56.5	60	73
M(mm)	1/2"	3/4"	1"	1-1/4"	1-1/2"	2"

Size(mm)	63x2"	75x2-1/2"	90x3"	110x4"
D(mm)	63	75	90	110
Z(mm)	37.5	44	51	61
L(mm)	73	85	94	110
M(mm)	2"	2-1/2"	3"	4"

MALE COUPLING

G09



Size(mm)	20x1/2"	25x3/4"	32x1	40x1-1/4"	50x1-1/2"	60x2"
D(mm)	20	25	32	40	50	60
Z(mm)	16	18	22.5	26	31	37.5
L(mm)	37.5	42	48	55.5	66	78
M(mm)	1/2"	3/4"	1"	1-1/4"	1-1/2"	2"

Size(mm)	63x2"	75x2-1/2"	90x3"	110x4"
D(mm)	63	75	90	110
Z(mm)	37.5	44	51	61
L(mm)	78	88	102	117
M(mm)	2"	2-1/2"	3"	4"

REDUCING RING

G10



Size(mm)	25x20	32x20	32x25	40x32	50x40	63x50
D(mm)	20	20	25	32	40	50
D1(mm)	25	32	32	40	50	63
Z(mm)	18	18	22.2	22.2	26	31
L(mm)	23	23	28	30	34	40

MALE UNION

G11



Size(mm)	20x1/2"	25x3/4"	32x1	40x1-1/4"	50x1-1/2"	60x2"
D(mm)	64	70	80	86	94	103
Z(mm)	1/2"	3/4"	1"	1-1/4"	1-1/2"	2"
L(mm)	21	21	21	26	29	35
M(mm)	60	62	64	68	73	79

UNION

G12



ITEM No.	12011201	12011202	12011203	12011204	12011205	12011206
Size(mm)	20	25	32	40	50	63
D(mm)	20	25	32	40	50	63
L(mm)	44	50	61	72	81	93
H(mm)	48	55	64	78	86	102
Z(mm)	16	18	22.5	25	31	37.5

UNION

G13



Size(mm)	20	25	32
D(mm)	20	25	32
D1(mm)	27.6	32.6	40.6
D2(mm)	44.0	49.0	58.8
L(mm)	40.0	45.0	55.0
L1(mm)	20.0	21.0	23.5

45° ELBOW

G14



Size(mm)	20	25	32	40	50	60	63	75	90	110
D(mm)	20	25	32	40	50	60	63	75	90	110
Z(mm)	16	18	22.5	26	31	37.5	37.5	44	51	61
L(mm)	21.5	25.6	31.0	36.5	44.5	51.5	51.5	63.5	74.5	93.5

FEMALE TEE

G15



Size(mm)	20X1/2"	25X3/4"	32X1"
D(mm)	20	25	32
Z(mm)	16	18	22.5
L(mm)	37	32	40
L1(mm)	29	34	41

END CAP

G16



Size(mm)	20	25	32	40	50	60	63	75	90	110
D(mm)	20	25	32	40	50	60	63	75	90	110
Z(mm)	18	18	22.5	26	31	37.5	37.5	44	51	61
L(mm)	22	25	28	33	40	50	50	56	65	80

FEMALE TEE(COPPER THREAD)

G17



Size(mm)	20X1/2"	25X1/2"	25X3/4"
D(mm)	20	25	25
Z(mm)	16	18.5	18.5
L(mm)	27	32	32
L1(mm)	29	34	40

FEMALE ELBOW(COPPER THREAD)

G18



Size(mm)	20X1/2"	25X1/2"	25X3/4"
D(mm)	20	25	25
Z(mm)	16	18.5	18.5
L(mm)	27	32	32
L1(mm)	29	34	40

FEMALE COUPLING (COPPER THREAD)

G19

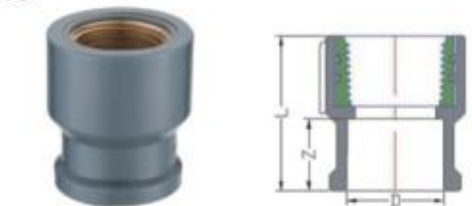

Size(mm)	20X1/2"	25X1/2"	25X3/4"
D(mm)	20	25	25
Z(mm)	16	18.5	18.5
L(mm)	37	40	40

REDUCING COUPLING

G20

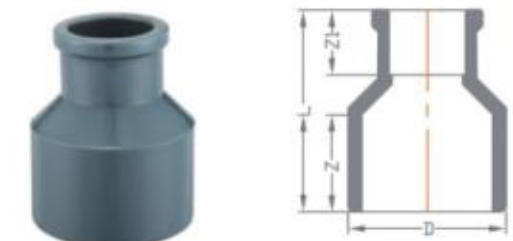

Size(mm)	32X20	40x20	40x25	50x20	50x25	50x32
D(mm)	32	40	40	50	50	50
Z(mm)	22.5	26	26	31	31	31
Z1(mm)	16	16	18.5	16	18.5	22.5
L1(mm)	42	51	51	61	61	61

PVC FITTINGS FOR WATER DRAINAGE WITH EXPANDING(DIN)



REDUCING TEE



Size(mm)	75x50	110x50	110x75	160x110
D(mm)	50	75	110	160
L(mm)	41	51	51	65
Z(mm)	81	94	105	141
Z1(mm)	81	94	98	122.5
Z2(mm)	92	102	111	152

ELBOW



Size(mm)	50	75	110	160
D(mm)	50	75	110	160
L(mm)	36	41	51	65
Z(mm)	73	89	114	164

TEE



Size(mm)	50	75	110	160
D(mm)	50	75	110	160
L(mm)	36	41	51	65
Z(mm)	74.5	93.5	122.5	160
Z1(mm)	145	182.5	239.5	325.5

45 DEG ELBOW



Size(mm)	50	75	110	160
D(mm)	50	75	110	160
L(mm)	36	41	51	65
Z(mm)	59.4	70.0	122.5	160
Z1(mm)	54.5	64.5	85.3	118.3

SKEW TEE



Size(mm)	50	75	110	160
D(mm)	50	75	110	160
L(mm)	36	41	51	65
L1(mm)	102	138	193	287
Z(mm)	54	65	89	109
Z1(mm)	120	138	193	287

SKEW CROSS



Size(mm)	110
D(mm)	110
L(mm)	51
Z(mm)	193
Z1(mm)	86

REDUCING SKEW TEE WITH SOCKET



Size(mm)	75x50	110x50	110x75
D(mm)	75	110	110
D1(mm)	75	110	110
D2(mm)	50	50	75
L(mm)	41	51	51
L1(mm)	165	188	225
L2(mm)	36	36	41

REDUCING COUPLING



Size(mm)	75x50	110x50	110x75
D(mm)	50	75	110
D1(mm)	75	110	110
L(mm)	36	41	41
Z(mm)	116	143	135

PVC-U THREADED FITTINGS FOR WATER SUPPLY (BS THREAD)



MALE COUPLING 101

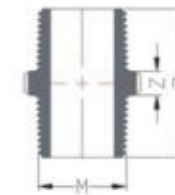

ITEM No.	1101011	1101012	1101013	1101014	1101015	1101016	1101017	1101018	1101019
Size(mm)	1/2"	3/4"	1"	1-1/4"	1-1/2"	2"	2-1/2"	3"	4"
L(mm)	42	44	50	56	58	65	78	84	90
Z(mm)	8	8	8	9	9	9	10	10	10
M(mm)	1/2"	3/4"	1"	1-1/4"	1-1/2"	2"	2-1/2"	3"	4"

MALE & FEMALE ADAPTER 102

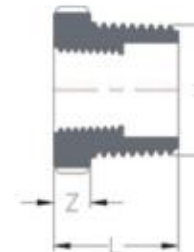

ITEM No.	1101020	1101021	1101022	1101023	1101024	1101025	1101026
Size(mm)	3/4"x1/2"	1/2"x1/2"	1/2"x3/4"	1-1/4"x3/4"	1-1/4"x1"	1-1/2"x3/4"	1-1/2"x3/4"
L(mm)	26	30	30	36	36	36	36
Z(mm)	8	8	8	9	9	10	10
M(mm)	3/4"	1"	1"	1-1/4"	1-1/4"	1-1/2"	1-1/2"

ITEM No.	1101027	1101028	1101029	1101030	1101031	1101032
Size(mm)	1-1/2"x1"	1-1/2"x1-1/4"	2"x1"	2"x1-1/4"	2"x1-1/2"	2-1/2"x1-1/4"
L(mm)	37	37	43	43	43	44
Z(mm)	10	10	11	11	11	12
M(mm)	1-1/2"	1-1/2"	2"	2"	2"	2-1/2"

ITEM No.	1101023	1101024	1101025	1101026	1101027	1101028	1101029
Size(mm)	2-1/2"x1-1/2"	2-1/2"x2"	3"x1-1/2"	3"x2"	3x2-1/2"	4x2-1/2"	4x3"
L(mm)	44	44	49	49	49	54	54
Z(mm)	12	12	13	13	13	14	14
M(mm)	2-1/2"	2-1/2"	3"	3"	3"	4"	4"

FEMALE ELBOW 103



ITEM No.	1101030	1101031	1101032	1101033	1101034	1101035	1101036	1101037	1101038	1101039
Size(mm)	1/2"	3/4"	1"	1-1/4"	1-1/2"	2"	2-1/2"	3"	4"	
L(mm)	28	32	38	46	50	61	74.5	85	99.5	
M(mm)	1/2"	3/4"	1"	1-1/4"	1-1/2"	2"	2-1/2"	3"	4"	
Z(mm)	17	19	22	26.5	26.5	31.5	32	36	40	

FEMALE REDUCING TEE 104



ITEM No.	1101040	1101041	1101042
Size(mm)	3/4"x1/2"	1"x1/2"	1"x3/4"
M(mm)	29	33	36
L(mm)	19	22	22
Z(mm)	1/2"	3/4"	1"

FEMALE TEE 105



ITEM No.	1101050	1101051	1101052	1101053	1101054	1101055	1101056	1101057	1101058	1101059
Size(mm)	1/2"	3/4"	1"	1-1/4"	1-1/2"	2"	2-1/2"	3"	4"	
L(mm)	28	32	38	46	50	61	74.5	85	99.5	
Z(mm)	17	19	22	26.5	26.5	31.5	32	36	40	
M(mm)	1/2"	3/4"	1"	1-1/4"	1-1/2"	2"	2-1/2"	3"	4"	

FEMALE COUPLING 106



ITEM No.	1101060	1101061	1101062	1101063	1101064	1101065	1101066	1101067	1101068	1101069
Size(mm)	1/2"	3/4"	1"	1-1/4"	1-1/2"	2"	2-1/2"	3"	4"	
L(mm)	37	40	47	51.5	53.5	59.5	72	78	84	
Z(mm)	3	3	3	3.5	3.5	3.5	4	4	4	
M(mm)	1/2"	3/4"	1"	1-1/4"	1-1/2"	2"	2-1/2"	3"	4"	

FEMALE UNION 107

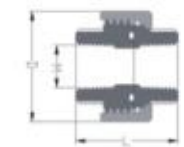

ITEM No.	1101070	1101071	1101072	1101073	1101074	1101075	1101076	1101077	1101078	1101079
Size(mm)	1/2"	3/4"	1"	1-1/4"	1-1/2"	2"	2-1/2"	3"	4"	
L(mm)	44	5	61	72	81	93	101	114	144	
Z(mm)	12	3/4"	1"	1-1/4"	1-1/2"	2"	2-1/2"	3"	4"	
M(mm)	48	55	64	78	85	102	136	152	182	

MALE PLUG 108

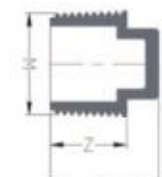

ITEM No.	1101080	1101081	1101082	1101083	1101084	1101085
Size(mm)	1/2"	3/4"	1"	1-1/4"	1-1/2"	2"
L(mm)	27	30	35	38.5	39.5	46.5
Z(mm)	1/2"	3/4"	1"	1-1/4"	1-1/2"	2"
M(mm)	17	19	22	26.5	26.5	31.5

**FEMALE REDUCER
I09**

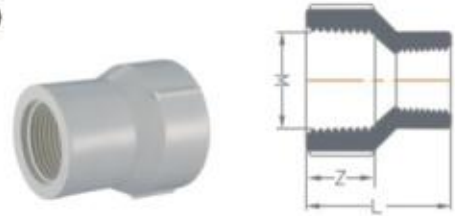

ITEM No.	11010901	11010902	11010903
Size(mm)	3/4"x1/2"	1"x1/2"	1"x3/4"
D(mm)	40	45	45
L(mm)	1/2"	3/4"	1"
Z(mm)	19	22	22

**UNION
I10**



ITEM No.	11011201	11011202	11011203	11011204	11011205	11011206	11011207
Size(mm)	1/2"	3/4"	1"	1-1/4"	1-1/2"	2"	2-1/2"
D(mm)	55	64	64	78	86	102	136
L(mm)	63	78	78	83	88	94	109
Z(mm)	25	26	26	26	29	31	43

**Female Union
I11**



ITEM No.	11011301	11011302	11011303
Size(mm)	1/2"	3/4"	1"
L(mm)	32	38	38
L1(mm)	47	55	55
Z(mm)	19	22	22

**Female & Male Union Elbow
I12**



ITEM No.	11011301	11011302	11011303
Size(mm)	1/2"	3/4"	1"
L(mm)	32	38	38
L1(mm)	47	55	55
Z(mm)	19	22	22

**Male & Female Elbow
I13**



ITEM No.	11011501	11011502	11011503	11011504	11011505	11011506	11011507	11011508	11011509
Size(mm)	1/2"	3/4"	1"	1-1/4"	1-1/2"	2"	2-1/2"	3"	4"
L(mm)	28	32	38	46	50	61	74.5	85	99.5
L1(mm)	35	37	43	51	56	66	80	92	107
Z(mm)	17	19	22	26.5	26.5	31.5	32	36	40

**Elbow With Plate
I14**



ITEM No.	11011601
Size(mm)	1/2"
M(mm)	1/2"
L(mm)	28
Z(mm)	17

**Reduced Elbow
I15**



ITEM No.	11011701	11011702
Size(mm)	3/4" X 1/2"	1" X 3/4"
M(mm)	3/4"	1"
M1(mm)	1/2"	3/4"
Z(mm)	19	22
Z1(mm)	17	19
L(mm)	31	35.4
L1(mm)	30	34.5

**UNION
I16**

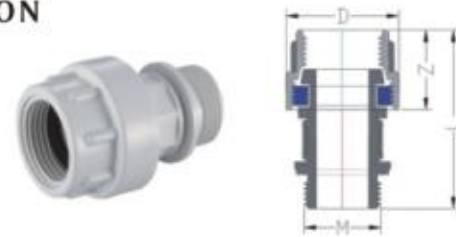

ITEM No.	11011801
Size(mm)	1"
L(mm)	74
M(mm)	1"
Z(mm)	33.5
D(mm)	53

**CILP
I17**



ITEM No.	11011901	11011902
Size(mm)	20	25
L(mm)	25.5	31.5
Z(mm)	26	33

**MALE UNION
I18**



ITEM No.	11012001	11012002	11012003	11012004	11012005	11012006
Size(mm)	20x1/2"	25x3/4"	32x1"	40x1-1/4"	50x1-1/2"	63x2"
L(mm)	60	62	64	68	73	79
M(mm)	1/2"	3/4"	1"	1-1/4"	1-1/2"	2"
Z(mm)	21	21	21	26	29	35
D(mm)	64	70	80	86	94	103

**REDUCING MALE ADAPTER
I19**

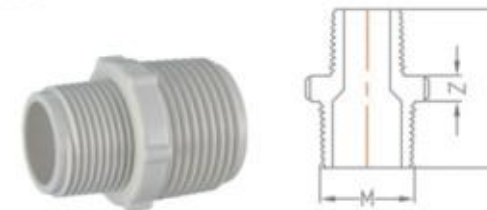

ITEM No.	11012101	11012102	11012103
Size(mm)	3/4"x1/2"	1x1/2"	1"x3/4"
L(mm)	44	47	49
M(mm)	3/4"	1	1
Z(mm)	8	8	8

**END CAP
I20**

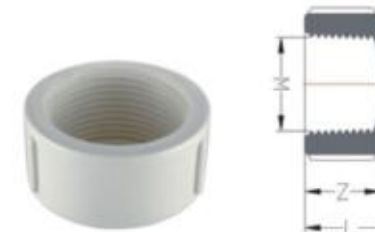

ITEM No.	11012201	11012202	11012203	11012204	11012205	11012206	11012207	11012208	11012209
Size(mm)	1/2"	3/4"	1"	1-1/4"	1-1/2"	2"	2-1/2"	3"	4"
L(mm)	17	19	22	26.5	26.5	31.5	45	50	55
M(mm)	1/2"	3/4"	1"	1-1/4"	1-1/2"	2"	2-1/2"	3"	4"
Z(mm)	22	24	27	32	33	38	40	45	50

**FEMALE ELBOW WITH BRASS
I21**

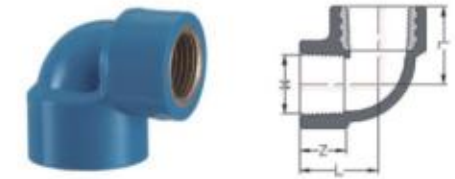

ITEM No.	11012301	11012302	11012303
Size(mm)	1/2"x1/2"	3/4"x3/4"	3/4"x1/2"
L(mm)	28	32	38
M(mm)	17	19	32
Z(mm)	1/2"	3/4"	1"

**FEMALE COUPLING WITH BRASS
I22**

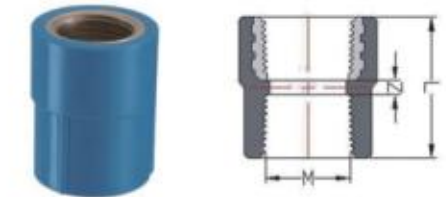

ITEM No.	11012401
Size(mm)	1/2"
L(mm)	1/2"
M(mm)	38
Z(mm)	3

**FEMALE TEE WITH BRASS
I23**

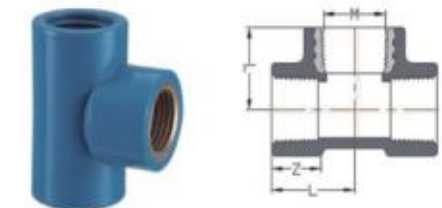

ITEM No.	11012501
Size(mm)	1/2"
L(mm)	1/2"
M(mm)	28
Z(mm)	17

**TOOL
I24**



ITEM No.	11012401	11012402
Size(mm)	20-32	20-63

PP COMPRESSION FITTINGS



COUPLING J01



D	DN	PN	E	L	Z
20	15	16	46	55	3
25	20	16	55	62	4
32	25	16	63	68	4
40	32	16	80	82	5
50	40	16	96	102	8
63	50	16	115	123	8
75	65	10	129	145	10
90	80	10	155	160	10
110	100	10	184	205	12

REDUCING COUPLING J02



DXD1	DN	PN	E	L	E1	Z
25X20	20	16	55	130	46	3
32X20	25	16	63	132	46	3
32X25	25	16	63	138	55	4
40X25	32	16	80	160	55	4
40X32	32	16	80	165	63	5
50X25	40	16	96	173	55	4
50X32	40	16	96	182	63	5
50X40	40	16	96	200	80	5
63X32	50	16	115	202	63	4
63X40	50	16	115	214	80	5
63X50	50	16	115	240	96	8
75X50	65	10	129	268	96	8
75X63	65	10	129	293	115	8
90X63	80	10	155	304	115	8
90X75	80	10	155	328	129	10
110X90	100	10	184	380	155	10
110X75	100	10	184	373	129	10

MALE ADAPTOR J03



DXG	DN	PN	E	L	Z
20X1/2"	15X15	16	46	83	16
20X3/4"	15X20	16	46	85	18
20X1"	15X25	16	46	87	20
25X1/2"	20X15	16	55	91	16
25X3/4"	20X20	16	55	93	18
25X1"	20X25	16	55	95	20
32X3/4"	25X20	16	63	98	18
32X1"	25X25	16	63	100	20
32X1-1/4"	25X32	16	63	105	25
40x1"	32x25	16	80	103	20
40x1-1/4"	32x32	16	80	108	25
40x1-1/2"	32x40	16	80	110	27
50x1"	40x25	16	96	125	20
50x1-1/4"	40x32	16	96	130	25
50x1-1/2"	40x40	16	96	132	27
50x2"	40x50	16	96	135	30
63x1-1/4"	50x32	16	115	145	25
63x1-1/2"	50x40	16	115	150	27
63x2"	50x50	16	115	153	30
63x2-1/2"	50x65	16	115	156	33
75x1-1/2"	65x40	10	129	178	27
75x2"	65x50	10	129	180	30
75x2-1/2"	65x65	10	129	183	33
75x3"	65x80	10	129	185	35
90x2"	80x50	10	155	198	30
90x2-1/2"	80x65	10	155	200	33
90x3"	80x80	10	155	201	35
90x4"	80x100	10	155	206	40
110x2-1/2"	100x65	10	184	243	33
110x3"	100x80	10	184	245	35
111x4"	100x100	10	184	250	40

ELBOW J04



D	DN	PN	E	L	Z
20	15	16	46	45	12
25	20	16	55	55	20
32	25	16	63	60	23
40	32	16	80	70	25
50	40	16	96	84	27
63	50	16	115	102	34
75	65	10	129	121	46
90	80	10	155	135	48
110	100	10	184	190	65

FEMALE ADAPTOR

J05

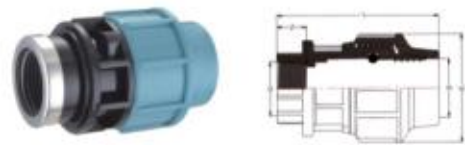

DXG	DN	PN	E	L	Z
20X1/2"	15X15	16	46	73	16
20X3/4"	15X20	16	46	75	18
20X1"	15X25	16	46	77	20
25X1/2"	20X15	16	55	84	16
25X3/4"	20X20	16	55	86	18
25X1"	20X25	16	55	88	20
32X3/4"	25X20	16	63	92	18
32X1"	25X25	16	63	94	20
32X1-1/4"	25X32	16	63	99	25
40x1"	32x25	16	80	108	20
40x1-1/4"	32x32	16	80	113	25
40x1-1/2"	32x40	16	80	115	27
50x1-1/4"	40x32	16	96	131	25
50x1-1/2"	40x40	16	96	133	27
50x2"	40x50	16	96	135	30
63x1-1/4"	50x32	16	115	149	25
63x1-1/2"	50x40	16	115	151	27
63x2"	50x50	16	115	154	30
63x2-1/2"	50x65	16	115	157	33
75x1-1/2"	65x40	10	129	180	27
75x2"	65x50	10	129	183	30
75x2-1/2"	65x65	10	129	186	33
75x3"	65x80	10	129	188	35
90x2"	80x50	10	155	196	30
90x2-1/2"	80x65	10	155	199	33
90x3"	80x80	10	155	201	35
90x4"	80x100	10	155	206	40
110x2-1/2"	100x65	10	184	246	33
110x3"	100x80	10	184	248	35
111x4"	100x100	10	184	253	40

TEE

J06



D	DN	PN	E	L	Z
20	15	16	46	45	12
25	20	16	55	55	20
32	25	16	63	60	23
40	32	16	80	70	25
50	40	16	96	84	27
63	50	16	115	102	34
75	65	10	129	121	46
90	80	10	155	136	48
110	100	10	184	190	65

MALE ELBOW

J07



DXG	DN	PN	E	L	Z	Z1
20X1/2"	15X15	16	46	70	12	16
20X3/4"	15X20	16	46	70	12	18
25X1/2"	20X15	16	55	82	20	16
25X3/4"	20X20	16	55	82	20	18
25X1"	20X25	16	55	82	20	20
32X1/2"	25x15	16	63	95	23	16
32X3/4"	25x20	16	63	95	23	18
32X1V	25x25	16	63	95	23	20
32X1-1/4"	25x32	16	63	95	23	25
40x1"	32x25	16	80	109	25	20
40x1-1/4"	32x32	16	80	109	25	25
40x1-1/2"	32x40	16	80	109	25	27
50x1-1/4"	40x32	16	96	134	27	25
50x1-1/2"	40x40	16	96	134	27	27
50x2"	40x50	16	96	134	27	30
63x1-1/4"	50x32	16	115	167	34	25
63x1-1/2"	50x40	16	115	167	34	27
63x2"	50x50	16	115	167	34	30
63x2-1/2"	50x65	16	115	167	34	33
75x2"	65x50	10	129	198	46	30
75x2-1/2H	65x65	10	129	198	46	33
75x3"	65x80	10	129	198	46	35
90x3"	80x80	10	155	220	48	35
90x4"	80x100	10	155	220	48	40
110x3"	100x80	10	184	278	65	40
111x4"	100x100	10	184	278	65	35

REDUCING TEE

J08

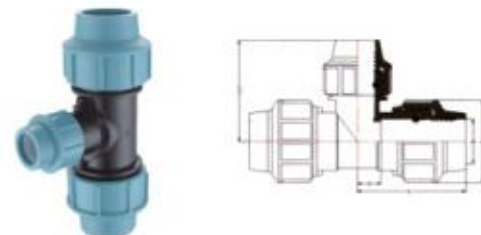

D	DN	PN	E	L	Z	L1
20X25x20	15	16	46	70	13	61
25x20x25	20	16	55	82	16	71
32x20x32	25	16	63	95	22	75
32x25x32	25	16	63	95	22	79
40x25x40	32	16	80	109	27	83
40x32x40	32	16	80	109	27	90
50x25x50	40	16	96	134	28	88
50x32x50	40	16	96	134	28	98
50x40x50	40	16	96	134	28	132
63x32x60	50	16	115	167	37	118
63x40x63	50	16	115	167	37	138
63x50x60	50	16	115	167	37	158
75x50x74	65	10	129	198	47	156
75x63x75	65	10	129	198	47	164
90x63x90	80	10	155	220	55	172
90x75x90	80	10	155	220	55	196
110x90x110	100	10	184	278	66	220

FEMALE ELBOW

J09



DXG	DN	PN	E	L	Z	Z1
20X1/2"	15X5	16	46	70	13	16
20X3/4"	15X20	16	46	70	13	18
25X1/2"	20X15	16	55	82	16	16
25X3/4"	20X20	16	55	82	16	18
25X1"	20X25	16	55	82	16	20
32X1/2"	25x15	16	63	95	22	16
32X3/4"	25x20	16	63	95	22	18
32X1"	25x25	16	63	95	22	20
32X1-1/4"	25x32	16	63	95	22	25
40x1"	32x25	16	80	109	27	20
40x1-1/4"	32x32	16	80	109	27	25
40x1-1/2"	32x40	16	80	109	27	27
50x1-1/4"	40x32	16	96	134	28	25
50x1-1/2"	40x40	16	96	134	28	27
50x2"	40x50	16	96	134	28	30
63x1-1/2"	50x40	16	115	167	37	27
63x2"	50x50	16	115	167	37	30
63x2-1/2"	50x65	16	115	167	37	33
75x2"	65x50	10	129	198	47	30
75x2-1/2"	65x65	10	129	198	47	33
75x3"	65x80	10	129	198	47	35
90x3"	80x80	10	155	220	55	35
90x4"	80x100	10	155	220	55	40
110x3"	100x80	10	184	278	66	35
111x4"	100x100	10	184	278	66	40

PLUG

J10



D	DN	PN	E	L	Z
20	15	16	46	56	50
25	20	16	55	66	60
32	25	16	63	87	80
40	32	16	80	90	83
50	40	16	96	105	98
63	50	16	115	124	115
75	65	10	129	153	145
90	80	10	155	166	155
110	100	10	184	210	200

FEMALE TEE

J11

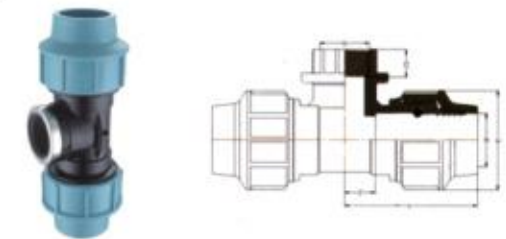

DXG	DN	PN	E	L	Z	Z1
20X1/2"	15X15	16	46	70	13	16
20X3/4"	15X20	16	46	70	13	18
25X1/2"	20X15	16	55	82	16	16
25X3/4"	20X20	16	55	82	16	18
25X1"	20X25	16	55	82	16	20
32X1/2"	25x15	16	63	95	22	16
32X3/4"	25x20	16	63	95	22	18
32X1"	25x25	16	63	95	22	20
32X1-1/4"	25x32	16	63	95	22	25
40x1"	32x25	16	80	109	27	20
40x1-1/4"	32x32	16	80	109	27	25
40x1-1/2"	32x40	16	80	109	27	27
50x1-1/4"	40x32	16	96	134	28	25
50x1-1/2"	40x40	16	96	134	28	27
50x2"	40x50	16	96	134	28	30
63x1-1/2"	50x40	16	115	167	37	27
63x2"	50x50	16	115	167	37	30
63x2-1/2"	50x65	16	115	167	37	33
75x2"	65x50	10	129	198	47	30
75x2-1/2"	65x65	10	129	198	47	33
75x3"	65x80	10	129	198	47	35
90x3"	80x80	10	155	220	55	35
90x4"	80x100	10	155	220	55	40
110x3"	100x80	10	184	278	66	35
111x4"	100x100	10	184	278	66	40

FLANGE

J12



D	DN	PN	E	L	F	H
40x1-1/2"	32X40	16	80	140	152	110
50x1-1/2"	40X40	16	96	165	152	110
50x2"	40X50	16	96	165	164	125
63x2"	50X50	16	115	194	164	125
63x2-1/2"	50X65	16	115	194	184	145
75x2-1/2"	65X65	10	129	209	184	145
75x3"	65X80	10	129	209	200	160
90x3"	80X80	10	155	229	200	160
90x4"	80X100	10	155	229	220	180
110x4"	100X100	10	184	256	220	180

**MALE TEE
J13**

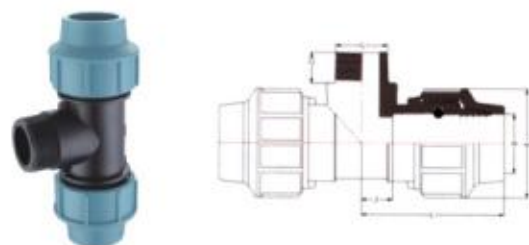

DXG	DN	PN	E	L	Z	Z1
20X1/2"	15X15	16	46	70	12	16
20X3/4"	15X20	16	46	70	12	18
25X1/2"	20X15	16	55	82	20	16
25X3/4"	20X20	16	55	82	20	18
25X1"	20X25	16	55	82	20	20
32X1/2"	25x15	16	63	95	23	16
32X3/4"	25x20	16	63	95	23	18
32X1"	25x25	16	63	95	23	20
32X1-1/4"	25x32	16	63	95	23	25
40x1"	32x25	16	80	109	25	20
40x1-1/4"	32x32	16	80	109	25	25
40x1-1/2"	32x40	16	80	109	25	27
50x1-1/4"	40x32	16	96	134	27	25
50x1-1/2"	40x40	16	96	134	27	27
50x2"	40x50	16	96	134	27	30
63x1-1/4"	50x32	16	115	167	34	25
63x1-1/2"	50x40	16	115	167	34	27
63x2"	50x50	16	115	167	34	30
63x2-1/2"	50x65	16	115	167	34	33
75x2"	65x50	10	129	198	46	30
75x2-1/2"	65x65	10	129	198	46	33
75x3"	65x80	10	129	198	46	35
90x3"	80x80	10	155	220	48	35
90x4"	80x100	10	155	220	48	40
110x3"	100x80	10	184	278	65	40
111x4"	100x100	10	184	278	65	35

**CLAMP SADDLE
J15**



DXG	DN	PN	L	Z	F
25X1/2"	20X15	16	58	30	78
25X3/4"	20X20	16	58	30	78
32X1/2"	25X15	16	58	30	78
32X3/4"	25X20	16	61	30	80
32X1"	25X25	16	61	30	80
40X1/2"	32X15	16	61	30	80
40X3/4"	32X20	16	70	30	80
40X1"	32X25	16	70	30	80
40X1-1/4"	32X32	16	70	30	80
50X1/2"	40X15	16	77	30	98
50X3/4"	40X20	16	77	30	98
50X1"	40X25	16	81	30	98
50X1-1/4"	40X32	16	83	30	98
63X1/2"	50X15	16	92	30	105
63X3/4"	50X20	16	92	30	105
63X1"	50X25	16	96	30	105
63X1-1/4"	50X32	16	98	30	105
63X1-1/2"	50X40	16	95	30	105
75X1/2"	65X15	10	108	30	123
75X3/4"	65X20	10	108	30	123
75X1"	65X25	10	109	30	123
75X1-1/4"	65X32	10	111	30	123
75X1-1/2"	65X40	10	115	30	123
75X2"	65X50	10	115	30	123
90X1/2"	80X15	10	123	35	132
90X3/4"	80X20	10	123	35	132
90X1"	80X25	10	123	35	132
90X1-1/4"	80X32	10	123	35	132
90X1-1/2"	80X40	10	123	35	132
90X2"	80X50	10	123	35	132
110X1/2"	100X15	10	140	40	163
110X3/4"	100X20	10	140	40	163
110X1"	100X25	10	140	40	163
110X1-1/4"	100X32	10	140	40	163
110X1-1/2"	100X40	10	140	40	163
110X2"	100X50	10	140	40	163
125X1/2"	125X15	10	195	40	180
125X3/4"	125X20	10	195	40	180
125X1"	125X25	10	195	40	180
125X1-1/4"	125X32	10	195	40	180
125X1-1/2"	125X40	10	195	40	180
125X2"	125X50	10	195	40	180

**ELBOW WALL PLATE
J14**



D	DN	PN	E	L	Z	L1	Z1	L2
20x1/2"	15X15	16	46	67	17	31	16	30
25x3/4"	20X20	16	55	81	21	38	18	37



Raw materials:u-pvc



Raw materials:u-pvc

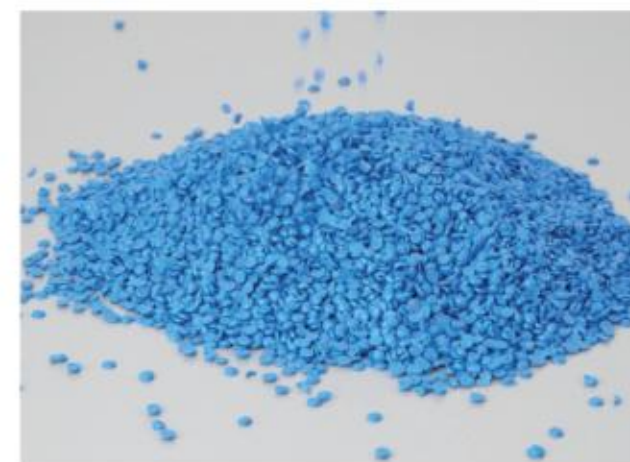

Raw materials:u-pvc



Raw materials:c-pvc



Raw materials:ABS



Raw materials:PP-R